

Distance Laser Sensor

**DLS-C 15 / DLS-C 30
DLS-CH 15 / DLS-CH 30**

**FLS-C 10 / FLS-C 30
FLS-CH 10 / FLS-CH 30**

Technical Reference Manual

V5.01

Please check www.dimetix.com
for the latest version

This Manual is Valid for software version 0500 or later

Table of Contents

1 Introduction.....	4
1.1 Product identification.....	5
1.2 Components.....	5
1.3 Validity.....	5
2 Application examples.....	6
2.1 Serial interface RS-232 / RS-422.....	6
2.2 Analog and digital output.....	6
2.3 External display.....	6
2.4 External trigger.....	6
2.5 SSI connection.....	7
2.6 Positioning.....	7
3 Device overview and setup.....	8
3.1 Connection for configuration.....	8
3.2 Output interfaces.....	9
3.2.1 Output configuration example.....	9
3.3 Operation modes.....	10
3.3.1 Controlled mode.....	10
3.3.2 Stand-alone mode.....	11
3.4 Measuring characteristics.....	12
3.4.1 Measuring characteristics overview.....	12
3.4.2 Moving target characteristic.....	13
3.4.3 Error behavior.....	14
3.5 Special user commands.....	15
3.5.1 Offset / Gain.....	15
3.5.2 Output format.....	15
3.6 Output value filter.....	16
3.6.1 Moving average filter.....	16
3.6.2 Spike suppression filter.....	16
3.6.3 Error suppression filter.....	16
4 Installation.....	17
4.1 Mounting.....	17
4.1.1 Mounting of the device.....	17
4.1.2 Mounting for the reflective plate.....	17
4.1.3 Alignment of the laser beam.....	17
4.1.4 Laser Life time consideration.....	17
4.2 Device wiring.....	17
4.2.1 Power supply.....	17
4.2.2 Cable connection.....	17
4.2.3 Shield and ground.....	17
4.2.4 Serial connection.....	18
4.2.5 Analog / Digital connection.....	19
4.2.6 SSI connection.....	19
4.2.7 External trigger connection.....	19
5 Technical data.....	20
5.1 Measuring accuracy definition.....	20
5.2 Measuring performance influences.....	20
5.3 Prevention of erroneous measurements.....	21
5.3.1 Rough surfaces.....	21
5.3.2 Transparent surfaces.....	21
5.3.3 Wet, smooth, or high-gloss surfaces.....	21
5.3.4 Inclined, round surfaces.....	21
5.3.5 Multiple reflections.....	21
5.3.6 Influence of sun light.....	21
5.4 Specifications.....	22
6 Electrical components.....	23
6.1 ID switch.....	23
6.2 Reset switch.....	23
6.3 Digital output.....	23
6.4 Digital input.....	23
6.5 Analog output.....	24
6.6 RS-232 serial interfaces.....	24
6.7 RS-422 serial interface.....	24
6.8 SSI output.....	25
6.8.1 SSI Specification.....	25
6.8.2 SSI Timing.....	25
6.9 Connector.....	26
6.9.1 D-Sub connector.....	26

6.9.2 Screw terminal.....	26
7 Physical dimensions.....	27
8 Factory settings.....	27
8.1 Standard configuration.....	27
8.2 User configured measurement.....	27
9 Command set.....	28
9.1 General.....	28
9.1.1 Command termination <trm>.....	28
9.1.2 Device identification N.....	28
9.1.3 Parameter separator.....	28
9.1.4 Set/Get commands.....	28
9.1.5 Startup sequence.....	28
9.2 Operation commands.....	29
9.2.1 Distance measurement (sNg).....	29
9.2.2 Single sensor tracking (sNh).....	29
9.2.3 Single sensor tracking with timer(sNh).....	29
9.2.4 Tracking with buffering – Start (sNf).....	30
9.2.5 Read out - Tracking with buffering(sNq).....	30
9.2.6 STOP/CLEAR command (sNc).....	30
9.2.7 Signal measurement (sNm).....	30
9.2.8 Temperature measurement (sNt).....	31
9.2.9 Laser ON (sNo).....	31
9.2.10 Laser OFF (sNp).....	31
9.3 Configuration commands.....	32
9.3.1 Set communication parameter (sNbr).....	32
9.3.2 Measuring characteristic configuration (sNuc).....	33
9.3.3 Set auto start configuration (sNA).....	34
9.3.4 Set/Get analog output min level (sNvm).....	34
9.3.5 Set/Get analog output value in error case (sNve).....	34
9.3.6 Set/Get analog output distance range (sNv).....	35
9.3.7 Set/Get digital output levels (sNn).....	36
9.3.8 Configure digital input (sNDI1).....	37
9.3.9 Read digital input (sNRI).....	37
9.3.10 Interface 2 configuration (RS-422 / SSI).....	38
9.3.11 Set/Get error value on SSI output.....	39
9.3.12 Set/Get measurement filter configuration (sNfi).....	39
9.3.13 Save configuration parameters (sNs).....	39
9.3.14 Set configuration parameters to factory default (sNd).....	40
9.3.15 Get software version (sNsv).....	40
9.3.16 Get serial number (sNsn).....	40
9.3.17 Get device generation and type (dg).....	40
9.3.18 Get device type (dt).....	41
9.4 Special user operation commands.....	42
9.4.1 User distance measurement (sNug).....	42
9.4.2 User single sensor tracking (sNuh).....	42
9.4.3 User single sensor tracking with timer(sNuh).....	43
9.4.4 User tracking with buffering – Start (sNuf).....	43
9.4.5 Read out – User tracking with buffering (sNuq).....	43
9.5 Special User configuration commands.....	44
9.5.1 Set user auto start configuration (sNuA).....	44
9.5.2 Set/Get user distance offset (sNuof).....	44
9.5.3 Set/Get user distance gain (sNuga).....	44
9.5.4 User output protocol (sNuo).....	45
9.6 Error codes.....	46
10 Safety instructions.....	47
10.1 Use of the instrument.....	47
10.2 Limits to use.....	47
10.3 Areas of responsibility.....	48
10.4 Hazards in use.....	48
10.5 Laser classification.....	49
10.6 Electromagnetic compatibility (EMC).....	50
10.7 Producer Standards.....	50
10.8 Disposal.....	50
10.9 Labeling.....	51
10.10 Laser Specification.....	51
10.11 Maintenance.....	51
10.12 Service.....	51

1 Introduction

The DLS-C(H) and FLS-C(H) are powerful distance-measuring instruments for integration into industrial applications. They allow accurate and contactless distance measurement over a wide range using the reflection of a laser beam:

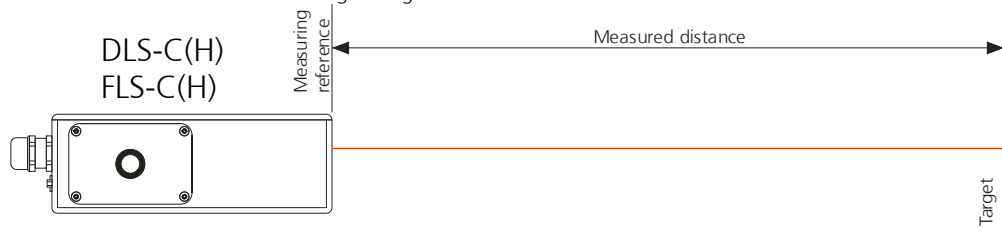

Fig. 1 Standard application

Key features

- Compatible with DIMETIX DLS-B(H) and DLS-A(H) Laser Distance Sensor
- Measurement range 0.05 to 500 m
- Serial interface (RS-232 and RS-422)
- SSI interface (FLS-C(H) only)
- Connection of up to 10 modules on a single RS-422 line
- Wide range power supply (9...30VDC), heating option (24...30VDC)
- Programmable analog output (0/4...20mA)
- Two programmable digital outputs (DO1 and DO2)
- Digital output for error signalization (DOE)
- One programmable digital input (DI1)
- ASCII protocol to control external displays
- D-Sub connector and screw terminal joint for easy connection of DLS-C(H) / FLS-C(H)
- IP65 (protected against ingress of dust and water)
- 4 LEDs for status signaling
- Complementary configuration software available at Dimetix web site (www.dimetix.com)
- Optional: Internal heater for device operation down to -40°C
- Laser class II (<0.95mW)
- Accessories for easy use of the sensor



Use of controls or adjustments or performance of procedures other than those specified in this Technical Reference Manual may result in hazardous radiation exposure.



For easy startup with the DLS / FLS sensor, please use our free configuration software from our web-page:

www.dimetix.com/UtilitySW

1.1 Product identification

The product is identified by the label on the top of the sensor:

DLS-C Version with a measurement rate of up to 6 Hz and a maximum measuring distance of 150m

	Typical Accuracy	
	1.5mm	3.0mm
Standard version	DLS-C 15 Part No.: 500622	DLS-C 30 Part No.: 500621
Extended temperature range	DLS-CH 15 Part No.: 500624	DLS-CH 30 Part No.: 500623

FLS-C Version with a measurement rate of up to 200 Hz and a maximum measuring distance of 500m

	Typical Accuracy	
	1.0mm	3.0mm
Standard version	FLS-C 10 Part No.: 600502	FLS-C 30 Part No.: 600501
Extended temperature range	FLS-CH 10 Part No.: 600504	FLS-CH 30 Part No.: 600503

1.2 Components

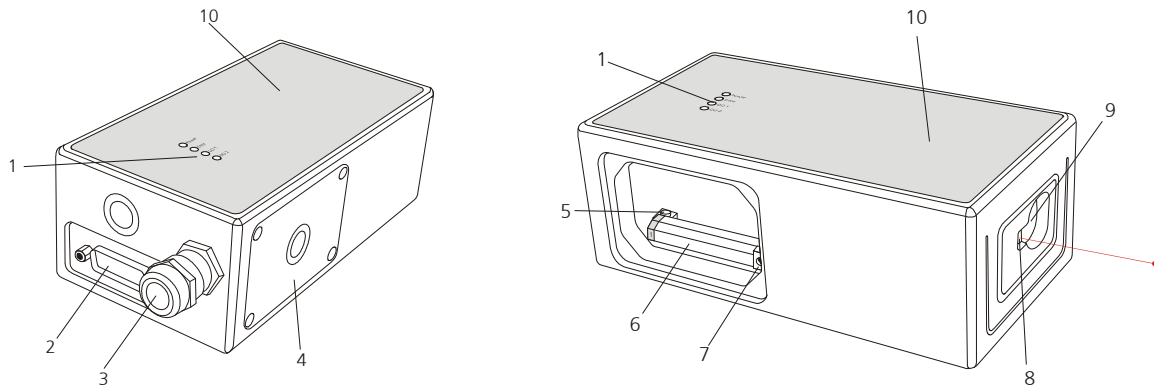

- | | |
|--|--|
| <p>1 Status LEDs
status signaling</p> <p>2 15-Pin D-Sub connector
RS-422, RS-232, SSI, analog, digital output</p> <p>3 Cable gland (M16 x 1.5mm)
for connection cable insertion</p> <p>4 Cover
provides access to the screw terminal</p> <p>5 Reset switch
resets the DLS-C(H)/FLS-C(H) to default settings</p> | <p>6 Screw terminal
RS-422, RS-232, SSI, analog, digital output</p> <p>7 ID switch
defines the Device ID for RS-422 operation</p> <p>8 Laser beam outlet</p> <p>9 Receiver optics</p> <p>10 Product label
see 10.9 Labeling on page 51</p> |
|--|--|

1.3 Validity

This manual is valid for DLS-C(H) and FLS-C(H) devices with the following software version:

Interface software version: **0500 or later**
Module software version: **0400 or later**

To get the software version use the command described in 9.3.15 *Get software version (sNsv)* on page 40

2 Application examples

Since the configuration of the DLS-C(H)/FLS-C(H) is very flexible the device is usable in various situations. The following application examples give an idea of possible applications. Please visit www.dimetix.com for a detailed description of the mentioned application examples and check for additional application examples.

2.1 Serial interface RS-232 / RS-422

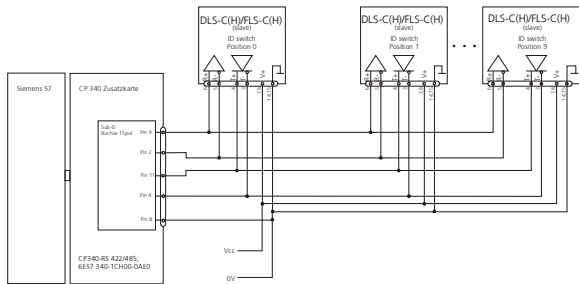

Fig. 2: RS-422 connection to S7 PLC

While the RS-232 should be used for the configuration of the device (See 3.1 Connection for configuration on page 8) the RS-422 is made for communication in industrial environment (See 3.3.1 Controlled mode on page 10 and 4.2.4 Serial connection on page 18).

Fig. 2 shows the connection of multiple DLS-C(H)/FLS-C(H) devices to a Siemens S7 PLC. A detailed application note can be found on www.dimetix.com.

For RS-422 connections use twisted pair cables only!

2.2 Analog and digital output

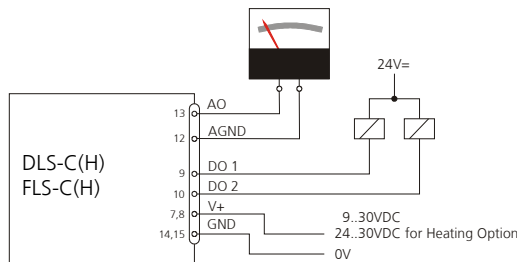

Fig. 3: AO and DO connection

Activate the stand-alone mode (3.3.2 Stand-alone mode on page 11) and the device is ready to use. It starts measuring after power on and updates the analog and digital output according to the configuration. See 9.3.4 and the following chapters for the configuration commands.

2.3 External display

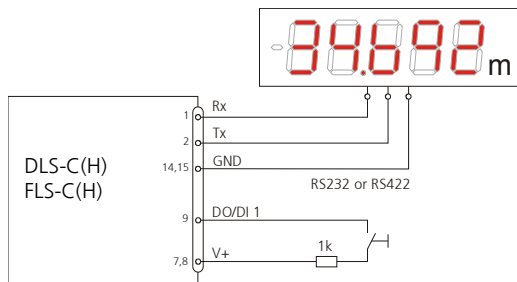

Fig. 4: External display connection

If Display Mode is enabled, the DLS-C(H)/FLS-C(H) formats the measured distance as ASCII string, which is understood by External Displays with a serial interface. Since the DLS-C(H)/FLS-C(H) transfers this formatted string automatically on the serial interface after completing a measurement. Measurement results can be displayed on an external display without an additional controller. Check www.dimetix.com for a detailed application note.

2.4 External trigger

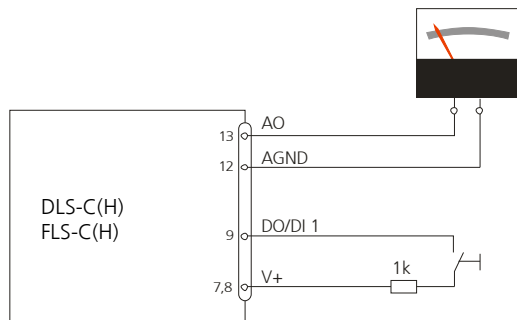
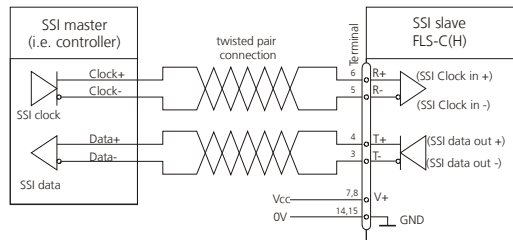

Fig. 5: Use digital input as external trigger

The DLS-C(H)/FLS-C(H) includes the option of triggering measurements with an external switch or push button on Digital Input 1 (DI 1). Using the Digital Input DI 1 disables the Digital Output DO 1.

Please refer to 3.3.2.2 Manual start configuration on page 11

2.5 SSI connection



Set the FLS-C(H) in stand-alone mode (3.3.2 Stand-alone mode on page 11) and connect it to a SSI master as shown in Fig. 6. The measured distances are immediately available at the SSI output. See 9.3.10 Interface 2 configuration (RS-422 / SSI) on page 38 for the detailed command description.

Never connect the SSI master before the FLS-C(H) interface 2 is configured as SSI interface.

Fig. 6: SSI connection example

2.6 Positioning

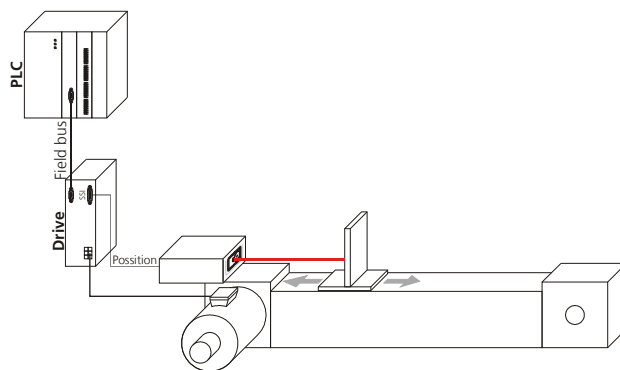

The figure on the left shows a typical positioning application. In this application the SSI interface of the FLS-C(H) is directly connected to a position input of a motor drive. The drive controls the motor in such a way, that the sledge moves to the position given as set point by the PLC.

The encoder is used for security reasons to double check the movement by the Drive.

In this applications the FLS-C(H) uses the SSI interface (4.2.6 SSI connection on page 19) and the moving target characteristic (3.4.2 Moving target characteristic on page 13).

Please check on www.dimetix.com for detailed application notes.

Fig. 7: Positioning application

3 Device overview and setup

We recommend that you carry out the configuration steps in an office before mounting the device, especially if you are not familiar with the DLS-C(H)/FLS-C(H).

Configure the outputs first and second do the configuration of the operation mode. The following sections describe the configuration steps and give an example.

3.1 Connection for configuration

To be able to configure the DLS-C(H)/FLS-C(H), it must be powered and connected to a PC. Figure 8 shows the necessary connections. On the PC, any terminal program can be used to communicate with the module. A configuration utility is also available on the web page www.dimetix.com.

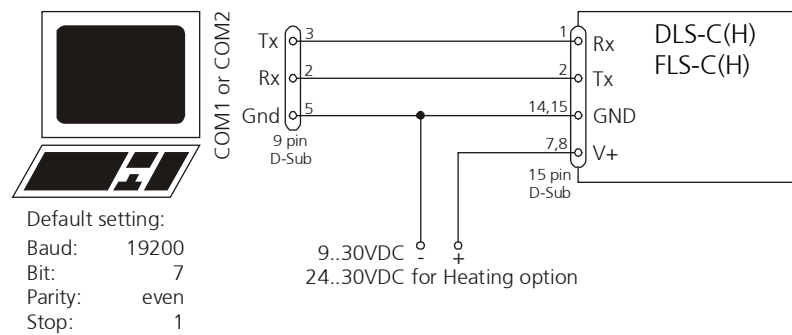

Fig. 8 Connection for DLS-C(H)/FLS-C(H) configuration

3.2 Output interfaces

The DLS-C(H)/FLS-C(H) contains different interfaces. Measurement results and errors are signaled at the outputs as described below.

RS-232	The RS-232 is meant for the configuration of the device, however measurement can also be taken using the RS-232 interface. Measurement results and/or error codes are sent corresponding to the command description. To use this interface host system is needed as described in 3.3.1 Controlled mode on page 10.
RS-422	The RS-422 operates like the RS-232, but it is an industrial interface and therefore not only usable for configuration but also for controlled measurement as described in 3.3.1 Controlled mode on page 10. The RS-422 can not be used simultaneous with the SSI interface since it uses the same signal lines.
SSI Output	The SSI Interface is only implemented in the FLS type. The SSI interface is updated after each successful measurement as well as after an error occurs. If the interface is activated, it is updated in all operation modes. Binary and Gray code as well as error signalization is supported. (See 4.2.6 SSI connection on page 19)
Analog Output	The analog output is updated in controlled and stand-alone mode. It is configurable and works with two ranges: - 0..20mA - 4..20mA
Digital Outputs	Three digital outputs are included in the DLS-C(H)/FLS-C(H). Two of them are programmable, while the third is used to signal an error state of the device. The digital outputs are updated in all operation modes.

3.2.1 Output configuration example

After connecting the DLS-C(H)/FLS-C(H), the following steps are necessary to configure the output behavior.

No.	Action	Comment	Command
1	Set current output range	Defines the current output range from 0 to 20mA or from 4 to 20mA. <i>Example for device 0:</i> Set current output range from 4mA to 20mA.	s0vm+1<trm> ¹⁾
2	Set distance range	Defines the minimum distance (D _{min}) and the maximum distance (D _{max}) for the current range of the analog output. <i>Example for device 0:</i> Set distance range from 0m to 10m	s0v+00000000+00100000<trm> ¹⁾
3	Set analog output in case of an error	Sets the current that should be applied in case of an error. <i>Example for device 0:</i> Set current to 0mA in case of an error.	s0ve+000<trm> ¹⁾
4	Configure digital output	Set the ON and OFF level for the digital outputs. <i>Example for device 0:</i> DO 1: off=2000mm on=2005mm DO 2: off=4000mm on=4005mm	s01+00020000+00020050<trm> ¹⁾ s02+00040000+00040050<trm> ¹⁾
5	Configure SSI Output	Activate SSI output (RS-422 is deactivated) <i>Example for device 0:</i> Set SSI configuration Set output value in error case to 12345	s0SSI+1<trm> ¹⁾ s0SSIE+12345<trm> ¹⁾
6	Save settings	The changed configuration must be saved to make it permanent. <i>Example for device 0:</i> Save settings for device 0	s0s<trm> ¹⁾

1) Commands are described in 9 Command set on page 28

Note: If the serial line settings of the device have been lost, please reset the configuration to the factory settings (8 Factory settings on page 27) using the reset button (6.2 Reset switch on page 23). Please note that the ID switch must be reset manually.

3.3 Operation modes

The first decision to be taken is the type of operating mode that will be used to perform distance measurements. While the controlled mode provides maximum flexibility and accuracy, it is often not suitable for integration into existing drives, PLCs or analog environments. In such cases the Stand-alone mode might be preferred.

controlled mode	stand-alone mode	
	Auto start	Manual start
The measurement is controlled by a host with commands such as - sNg - sNh - sNuf	The measurement starts after power on. This must be configured with the command - sNA - sNuA	After configuring the DO1 as DI1, the measurement can be triggered by an external signal. Use the following command - sNDI
See 9.2 Operation commands starting on page 29	See 9.3.3 Set auto start configuration (sNA) on page 34	See 9.3.8 Configure digital input (sNDI1) on page 37
After each measurement all outputs are updated corresponding to the configuration (See 9.3 Configuration commands on page 32).		

3.3.1 Controlled mode

In controlled mode, each operation of a DLS-C(H)/FLS-C(H) is triggered by a command sent from a host system over a serial line. While a single device can be connected to the host system using the RS-232 interface, up to 10 devices can be connected to a single serial RS-422 line. The related command set is described in Chapter 9 on page 28.

3.3.1.1 Configuration

After connecting the module, the steps below are necessary to configure the DLS-C(H)/FLS-C(H) for the controlled interface mode.

No.	Action	Comment	Command
1	Set ID switch	Changes to the Device ID are activated after a power cycle. <i>Example for device 0:</i> Change the ID Switch to position 0	Set ID switch to position 0 Power OFF; Wait 10s; Power ON
2	Set controlled mode	Set the DLS-C(H)/FLS-C(H) to the controlled mode, if not already in controlled mode. <i>Example for device 0:</i> Set to controlled mode by means of the stop command.	s0c<trm> ¹⁾
3	Set communication parameters	If necessary, change the settings for the serial interface. <i>Example for device 0:</i> Set serial interface to 19200 Baud, 8 Bit, no Parity	s0br+2<trm> ¹⁾ Power OFF; Wait 10s; Change settings on the host; Power ON

1) Commands are described in 9 Command set on page 28

Note: If the communication parameters of the device are lost, please reset the configuration to the factory settings (8 Factory settings on page 27) using the reset button (6.2 Reset switch on page 23). Please note that the ID switch must be reset manually.

3.3.1.2 Host software

Host software is required for operation of the DLS-C(H)/FLS-C(H) in controlled mode. When connecting multiple devices to a single serial line (RS-422), strict Master-Slave communication must be implemented (DLS-C(H)/FLS-C(H) operates as slave). For software sample-code or application-notes please consult our web site www.dimetix.com.

Careful testing of the host software together with the devices prior to installation is strongly recommended.

3.3.2 Stand-alone mode

Before starting the stand-alone mode, output configuration must be done (See 3.2 Output interfaces on page 9)

3.3.2.1 Auto start configuration

The following steps are necessary to configure the DLS-C(H)/FLS-C(H) for stand-alone mode with auto start.

No.	Action	Comment	Command
1	Set auto start	Set the DLS-C(H)/FLS-C(H) to the stand-alone mode with auto start and with the desired sample rate. <i>Example for device 0:</i> Set sample rate to fastest possible speed.	s0A+0<trm> ¹⁾

1) Commands are described in 9 Command set on page 28

Note: If the serial line settings of the device have been lost, please reset the configuration to the factory settings (8 Factory settings on page 27) using the reset button (6.2 Reset switch on page 23). Please note that the ID switch must be reset manually.

3.3.2.2 Manual start configuration

Configure the Digital Input (see 9.3.8 Configure digital input (sNDI1) on page 37) to activate the external trigger to start measurements.

No.	Action	Comment	Command
1	Activate digital input DI1	Defines the action for a trigger event on DI1. <i>Example for device 0:</i> Configure DI1 to start and stop tracking. If DI1 is high, distances are measured and the result is transferred to the output at all interfaces. If DI1 goes to low, the measurement stops	s0DI1+3<trm> ¹⁾
2	Save settings	The changed configuration must be saved to make it permanent. <i>Example for device 0:</i> Save settings for device 0	s0s<trm> ¹⁾

1) Commands are described in 9 Command set on page 28

Note: If the serial line settings of the device have been lost, please reset the configuration to the factory settings (8 Factory settings on page 27) using the reset button (6.2 Reset switch on page 23). Please note that the ID switch must be reset manually.

3.4 Measuring characteristics

Multiple measuring characteristics are available in the FLS-C measuring devices to meet different requirements for various applications. With these measuring characteristics measuring rate and accuracy can be optimized for special requirements.

The FLS-C measuring device at factory settings has an accuracy of ± 1 mm (FLS-C(H) 10) respectively ± 3 mm (FLS-C(H) 30) at 2σ . Measuring rate depends on environmental conditions such as target surface, distance, background light (e.g. sun light), etc. Good environmental conditions increase measuring rate (e.g. white target surface or orange reflective target plate and dark environment).

3.4.1 Measuring characteristics overview

Measuring characteristic	Measuring rate	Typical accuracy @ 2σ		Description	Available in DLS-C(H)				
		FLS-C(H) 10	FLS-C(H) 30		Available in FLS-C(H)	Error behavior ¹⁾	User Commands ²⁾	Normal Commands ²⁾	
Normal (factory setting)	max. 10 Hz ³⁾	± 1 mm	± 3 mm	Measuring range on natural surface: typical 65 m Configuration command: sNuc+0+0 ⁴⁾	✓	✓	A	✓	✓
Fast	max. 20 Hz ¹⁾	± 2 mm	± 6 mm	Increased measuring rate up to 20 Hz. Configuration command: sNuc+0+1 ⁴⁾	✓	✓	A	✓	✗
Precise	max. 6 Hz ¹⁾	$\sim \pm 0.8$ mm	$\sim \pm 2.4$ mm	Increased accuracy of ± 0.8 mm Surveying applications, short range applications etc. Configuration command: sNuc+0+2 ⁴⁾	✓	✓	A	✓	✗
Natural surface	max. 6Hz, can drop to 0.25Hz @ up to approx. 80m	$\sim \pm 5$ mm @ up to approx. 80m	$\sim \pm 15$ mm @ up to approx. 80m	Increased measuring range on natural surfaces: typical 80 meters Measuring against far away natural surfaces or bad reflective surfaces such as black synthetic granules, etc. Configuration command: sNuc+0+3 ⁴⁾	✓	✓	A	✓	✓
Timed	user programmed	variable	variable	The device does not check the signal condition to ensure the specified accuracy is reached, a measurement value is transferred to the output at a defined measuring rate. This mode serves for applications where the accuracy is not important but the reaction time is critical Configuration command: sNuc+1+1 ⁴⁾	✗	✓	A	✓	✓
Moving Target	250Hz fix, SSI can poll with up to 200Hz	± 1 mm	± 3 mm	The device measures to a continuously moving target and the distance changes without any jumps. This measurement characteristic supervises the max speed, checks for distance jumps and includes a special filter to eliminate errors occurring for only a very short time. Configuration command: sNuc+2+0 ⁴⁾ (with error freezing) sNuc+2+1 ⁴⁾ (without error freezing)	✓	✓	B	✓	✗

1) The behavior in case of an error depends on the configuration. See 3.4.3 Error behavior on page 14

2) Changed characteristics do not influence all commands

3) Good environmental conditions (e.g. white target surface or orange reflective target plate and dark environment).

4) For the description of the command see 9.3.2 Measuring characteristic configuration (sNuc) on Page 33

3.4.2 Moving target characteristic

For continuous movements of a target which typically appears in positioning applications like automatic warehouses there is a special measurement characteristic built into the FLS-C (H) called "Moving target" (See 2.6 Positioning on page 7 for a sample application)

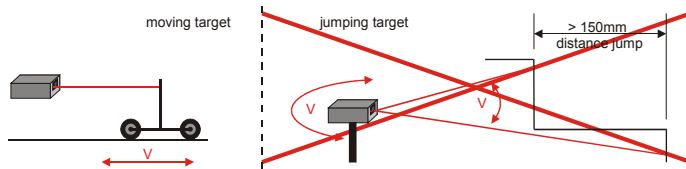

Fig. 9: Condition for moving target characteristic

To operate the FLS-C(H) in this measurement characteristic successfully, distance jumps must not occur. The laser beam must always hit the target.

This measurement characteristic combines a fast measurement rate with the unique accuracy of the FLS-C(H). The measurement rate is fixed and does not change during operation.

For RS-232, RS-422, analog and digital outputs, the output rate is 250Hz. The SSI interface can return reliable measurement data at up to 200Hz read out rate corresponding to the clock received from the master.

When measuring to a stopped target, the resulting distance will stay at a single value, it does not occur any deviation of the distance. This is necessary if the sensor is used for positioning in closed looped applications.

An optimized error handling suppresses short errors, that may occur by a short break of the laser beam. In addition an over speed detector (>10m/s) detects improper situations, which results in an error. This ensures robust operation in positioning applications.

The behavior of the device in case of a severe error can be defined by the operator (See 3.4.3 Error behavior on page 14).

For a description of the configuration command see 9.3.2 Measuring characteristic configuration (sNuc) on page 33.

3.4.3 Error behavior

The device has different error behaviors depending on the measuring characteristics and on the start operation.

3.4.3.1 A - Behavior

In case the device detects an error, this error is signalized at the outputs. On the serial and SSI output the error code will be visible depending on the configuration. The error will be visible at the output until the device performs a successful measurement and outputs the new distance value or the device will be reset by command (sNc) or by a power cycle.

3.4.3.2 B – Behavior (in moving target characteristic)

This error behavior is only relevant when using the moving target measurement characteristic.

Configuration \ Situation	with error freezing sNuc+2+0 ¹⁾	without error freezing sNuc+2+1 ¹⁾
Temporary error	The temporary error is converted into a permanent error. This error must be reset as described below.	The temporary error disappears as soon as the error condition is cleared (a successful measurement is done).
Permanent error	The permanent error must be reset as described below.	The permanent error must be reset as described below.

The error reset function depending on the start condition. The following diagram shows the error reset for the different start configurations.

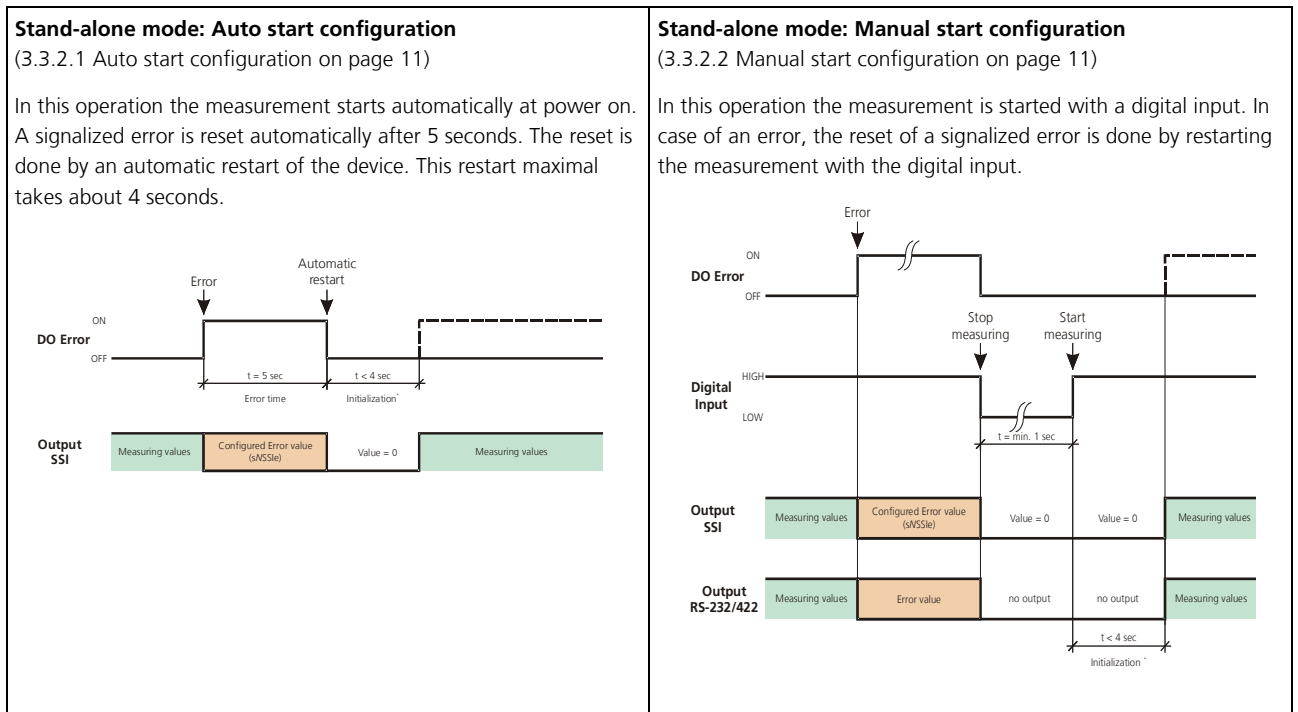

1) For the description of the command see 9.3.2 Measuring characteristic configuration (sNuc) on Page 33

3.5 Special user commands

The standard command set is extended by a special user command set, which makes it possible to change the output format and apply a offset and gain.



User command configuration do not influence Analog, Digital and SSI outputs.

3.5.1 Offset / Gain

The user can set an individual user gain and offset to create user defined output values. The output value is calculated as follows.

$Value_{User} = (Distance + Offset_{User}) \cdot \frac{GainNum_{User}}{GainDen_{User}}$	See 9.5.2 Set/Get user distance offset (sNuof) and 9.5.3 Set/Get user distance gain (sNuga) on page 44
---	---

With the offset and gain the result of the user commands (See 9.4 Special user operation commands on page 42) are changed only. Analog, Digital and SSI output values are not affected.

3.5.2 Output format

The DLS-C(H)/FLS-C(H) is able to format the output value on the serial interface (RS-232/RS-422) in order to fit it to an ASCII display. By the command `sNuo` the length of the output value can be defined as well as the position of the decimal point. This command in combination with a gain and offset allows the direct connection of an external display as described under 2.3 External display on page 6.

The command is described under 9.5.4 User output protocol (sNuo) on page 45

3.6 Output value filter

The DLS-C(H)/FLS-C(H) contains a filter for the measurement value, which can be activated and offers different configurations. This filter is available in the following Measuring characteristics (see 3.4 Measuring characteristics) on the DLS-C(H) and the FLS-C(H):

- Normal
- Fast
- Precise
- Natural Surface
- Timed

The output value filter is made of a moving average, a spike suppression as well as an error suppression filter. These filters are all configurable to offer most possible flexibility for the adaption of the DLS-C(H)/FLS-C(H) device to various applications.

This filter is inactive for the moving target characteristic.

3.6.1 Moving average filter

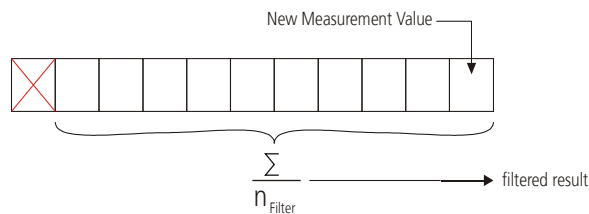

The moving average filter averages a specified number of measurements. Maximum 32 measurement values can be averaged. If a new measurement value is present, this value will be added to the filter values, while the last value will be removed. The sum of all measurement values divided by the size of the filter is transferred to all outputs.

Fig. 10 Moving average filter

3.6.2 Spike suppression filter

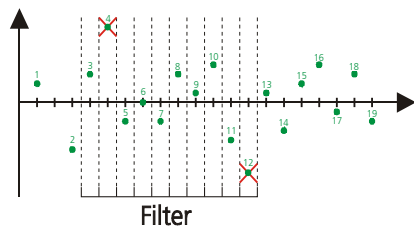

The spike suppression eliminates pairs of min max values inside the filter values (Number of filter values can be defined). Always the smallest and largest values are removed from the average calculation.

Fig. 11: Spike suppression filter

3.6.3 Error suppression filter

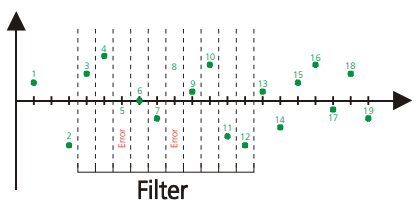

A maximum number of errors inside the filtered values can be suppressed. If the number of errors inside the filtered values is less as the specified value, no error is shown at the output

See 9.3.12 Set/Get measurement filter configuration (sNfi) on page 39

Fig. 12: Error suppression

4 Installation

4.1 Mounting

4.1.1 Mounting of the device

Three M4 threaded holes in the bottom of the DLS-C(H)/FLS-C(H) make it easy to mount the device.

Always obey all applicable safety regulations and never use the device outside the specifications stated under 5 Technical data on page 20.

4.1.2 Mounting for the reflective plate

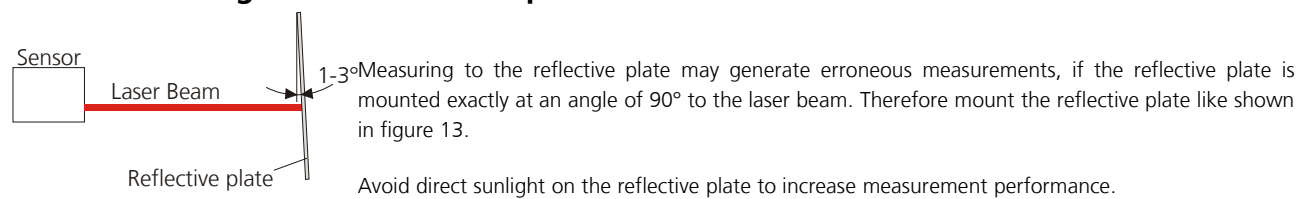

Fig. 13: Reflective Plate mounting

4.1.3 Alignment of the laser beam

Alignment of the laser beam is often difficult when the target is far away, as the laser spot is not visible. An optional telescopic viewfinder and an alignment jig is available to simplify the alignment procedure. (See www.dimetix.com for additional accessories and further details).

4.1.4 Laser Life time consideration

since the life time of the laser is limited, operate the device in a way, that the laser is switched on only when necessary. The laser life time stated under 5 Technical data on page 20 relates to the time while the laser is on.

4.2 Device wiring

4.2.1 Power supply

For trouble-free operation use a separate power supply for the DLS-C(H)/FLS-C(H).

FLS-C, DLS-C: 9...30V, 0.5A DC

FLS-CH, DLS-CH: 24...30V, 2.5A DC

4.2.2 Cable connection

A ferrite core must be fitted to the connecting cable. Use a ferrite core with an impedance of 150 Ω to 260 Ω at 25MHz and 640 Ω to 730 Ω at 100MHz. For example you can use KCF-65 from KE Kitagawa.

4.2.3 Shield and ground

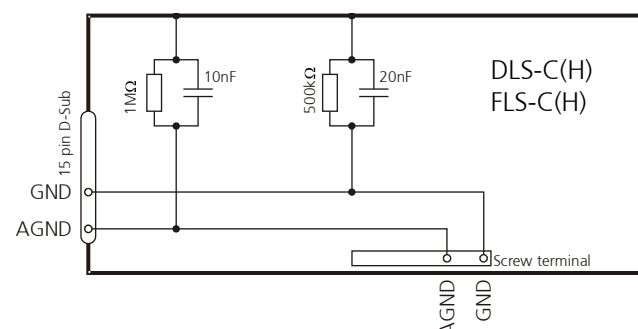

The DLS-C(H)/FLS-C(H) contains two electrically isolated grounds, the general ground (GND) and the analog ground (AGND). GND and AGND are connected to the housing by a RC element. Please see figure 19.

Fig. 14 Connection between shield and ground

4.2.4 Serial connection

This connection is mainly used for the controlled mode or to configure the device.

RS-232

Only point-to-point communication is possible when using the RS-232 interface.

Never connect multiple DLS-C(H)/FLS-C(H)s on a RS-232 serial line

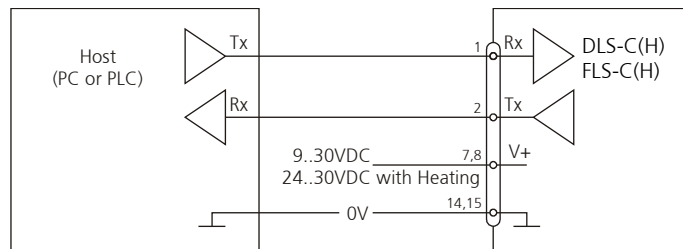

Fig. 15 Point-to-point connection with RS-232

RS-422

It is possible to connect multiple devices on a single RS-422 line. To ensure proper operation, strict Master-Slave communication must be applied. It is important, that the Master has full control of the communication and never initiates a new communication before termination of the previous communication (answer from the DLS-C(H)/FLS-C(H) or timeout).

For RS-422 connections use twisted pair cables only!

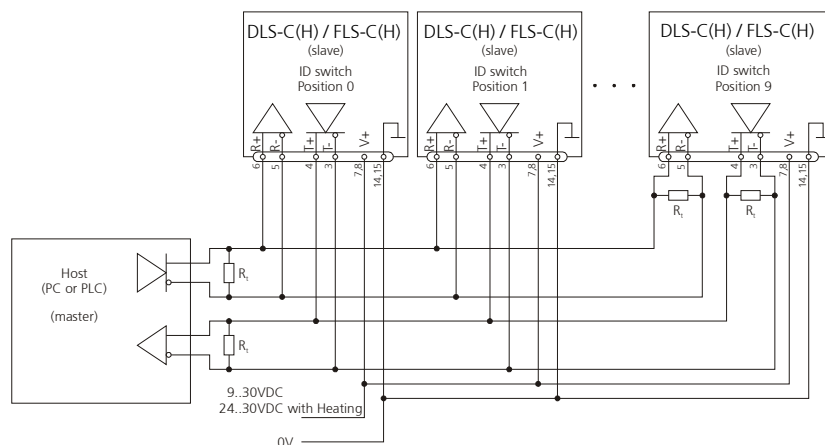

Fig. 16: Connecting multiple devices with RS-422



Ensure, that all DLS-C(H)/FLS-C(H)s are set to different ID numbers.



The RS-422 interface cannot be used simultaneous with the SSI interface.

4.2.5 Analog / Digital connection

This connection is mainly used with the stand-alone mode. The analog interface of the DLS-C(H)/FLS-C(H) is isolated from the rest of the device (See 4.2.3 Shield and ground on page 17). When using the analog interface, connect the analog ground (AGND). Make sure, that the total resistance in the analog path is lower than 500 Ω .

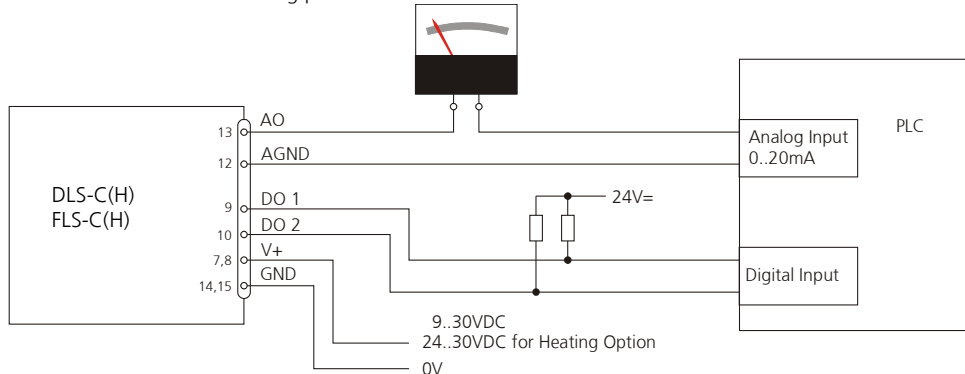

Fig. 17: Connection of an instrument and a PLC

4.2.6 SSI connection

Connect a SSI master according to the connection diagram in Fig. 18. It is compulsory to use a twisted pair cable. See 6.8 SSI output on page 25 and 6.8 SSI output on page 25 for additional information on the SSI interface.

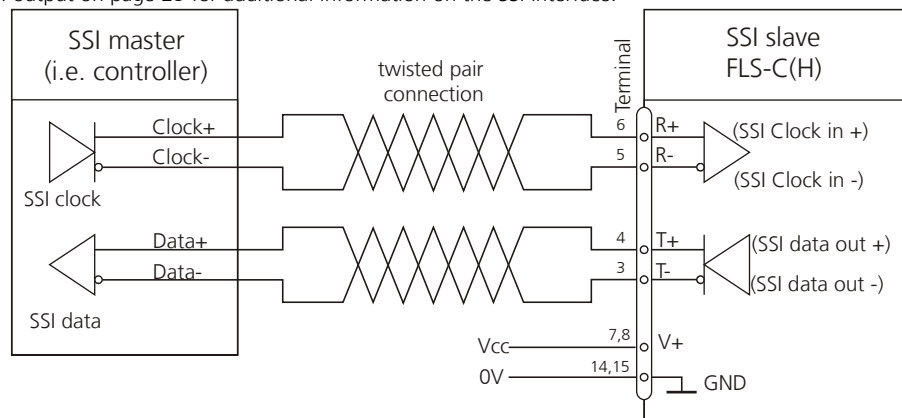

Fig. 18: Connection of a SSI Master



The RS-422 interface cannot be used simultaneous with the SSI interface.



The SSI Interface is implemented in the FLS-C(H) only.

4.2.7 External trigger connection

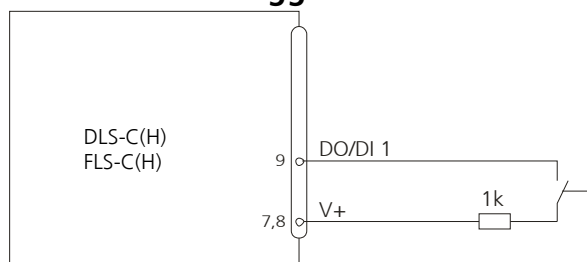

Fig. 19: Connection for external triggering

The DO1 (Digital Output 1) can also be used as digital input. For safety reasons, always use a resistor to protect the connection terminal. The function of digital input can be configured by the command sNDI1 (see 9.3.8 Configure digital input (sNDI1) on page 37)

5 Technical data

5.1 Measuring accuracy definition

The measuring accuracy corresponds to the ISO-recommendation ISO/R 1938-1971 with a statistical confidence level of 95.4% (i.e. \pm twice the standard deviation σ , refer to diagram on the right). The typical measuring accuracy relates to average conditions for measuring. It is $\pm 1.0\text{mm}$ for the FLS-C(H) 10, $\pm 1.5\text{mm}$ for the DLS-C(H) 15 and $\pm 3.0\text{mm}$ for the DLS-C(H)/FLS-C(H) 30 valid in the tracking mode.

Maximum deviation may occur under unfavorable conditions such as bright sunlight or when measuring to poorly reflecting or very rough surfaces. Measuring accuracy may deteriorate by approximately $\pm 0.02\text{mm/m}$ for distances above 30m.

The DLS-C(H)/FLS-C(H) does not compensate changes of atmospheric environment. These changes can influence the accuracy if measuring long distances ($>150\text{m}$) under conditions very different from 20°C , 60% relative humidity and 953 mbar air pressure. The influences of the atmospheric environment are described in

B.Edlen: "The Refractive Index of Air, Metrologia 2", 71-80 (1966)

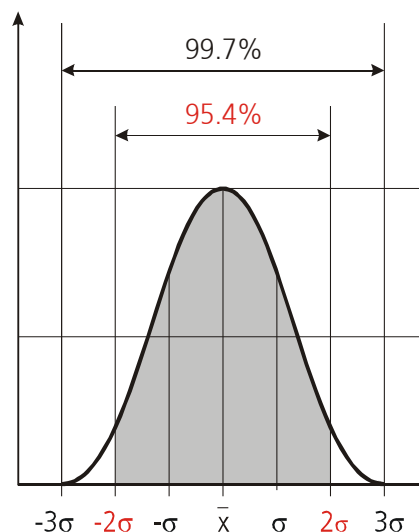

5.2 Measuring performance influences

The DLS-C(H)/FLS-C(H) is an optical instrument, whose operation is influenced by environmental conditions. Therefore, the measuring range achieved in use may vary. The following conditions may influence the measuring range:

Key	Factors increasing range	Factors reducing range
Target surface	Bright and reflective surfaces such as the target plates (See Accessories)	Matt and dark surfaces Green and blue surfaces
Airborne particles	Clean air	Dust, fog, heavy rainfall, heavy snowfall
Sunshine	Darkness	Bright sunshine on the target

The measurement range may be influenced by the configuration of the measurement characteristic. See 9.3.2 Measuring characteristic configuration (sNuc) on page 33.

The DLS-C(H)/FLS-C(H) does not compensate the influence of the atmospheric environment, which may be relevant when measuring long distances (e.g. $> 150\text{m}$). These effects are described in:

B.Edlen: "The Refractive Index of Air, Metrologia 2", 71-80 (1966)

5.3 Prevention of erroneous measurements

5.3.1 Rough surfaces

On a rough surface (e.g. coarse plaster), measure against the center of the illuminated area. To avoid measuring to the bottom of gaps in the surface use a target plate (see accessories on www.dimetix.com) or board.

5.3.2 Transparent surfaces

To avoid measuring errors, do not measure against transparent surfaces such as colorless liquids (such as water) or (dust-free) glass. In case of unfamiliar materials and liquids, always carry out a trial measurement.



Erroneous measurements can occur when aiming through glass panes or if there are several objects in the line of sight.

5.3.3 Wet, smooth, or high-gloss surfaces

- 1 Aiming at an "acute" angle deflects the laser beam. The DLS-C(H)/FLS-C(H) may receive a signal that is too weak (error message 255) or it may measure the distance targeted by the deflected laser beam.
- 2 If aiming at a right angle, the DLS-C(H)/FLS-C(H) may receive a signal that is too strong (error message 256).

5.3.4 Inclined, round surfaces

Measurement is possible as long as there is enough target surface area for the laser spot. On irregular and round surfaces the arithmetic average of the illuminated surfaces will be measured.

5.3.5 Multiple reflections

Erroneous measurements may occur if the laser beam is reflected by other objects than the target. Avoid any reflective object along the measurement path.

5.3.6 Influence of sun light

Aiming directly to the sun or the sun is exactly behind the target could make it impossible to measure distances.

5.4 Specifications

Typical measuring accuracy for DLS-C 15 / DLS-CH 15 ¹⁾ DLS-C 30 / DLS-CH 30 ¹⁾ FLS-C 10 / FLS-CH 10 ^{1,3,4)} FLS-C 30 / FLS-CH 30 ^{1,3)}	$\pm 1.5 \text{ mm @ } 2\sigma$ $\pm 3.0 \text{ mm @ } 2\sigma$ $\pm 1.0 \text{ mm @ } 2\sigma$ $\pm 3.0 \text{ mm @ } 2\sigma$
Accuracy of the analog output DLS-C(H) FLS-C(H)	(9.3.6 Set/Get analog output distance range (sNv) on page 35) 0.2% programmed span (12 Bit) 0.1% programmed span (12 Bit)
Typical repeatability for DLS-C 15 / DLS-CH 15 ¹⁾ DLS-C 30 / DLS-CH 30 ¹⁾ FLS-C 10 / FLS-CH 10 ¹⁾ FLS-C 30 / FLS-CH 30 ¹⁾	$\pm 0.4 \text{ mm @ } 2\sigma$ $\pm 0.5 \text{ mm @ } 2\sigma$ $\pm 0.3 \text{ mm @ } 2\sigma$ $\pm 0.5 \text{ mm @ } 2\sigma$
Smallest unit displayed	0.1 mm
Measuring range on natural surfaces	0.05 m to approx. 65 m (80m on natural surface characteristic ³⁾)
Measuring range on orange (reflective) target plate DLS-C(H) FLS-C(H)	Approx. 25 m to 150 m Approx. 0.5 m to 500 m
Measuring reference	from front edge (See 7 Physical dimensions)
Diameter of laser spot at target at a distance of	4mm @ 5m 8mm @ 10m 15mm @ 30m
Time for a measurement Single measurement: DLS-C(H) / FLS-C(H) ³⁾ Tracking: DLS-C(H) ³⁾ FLS-C(H) ³⁾	Typical: 0.3 s to 4 s Typical: 0.15 s to 4 s Typical: 4 ms to 4 s
Max target speed while moving target characteristic is active	Typical: 10m/s up to 150m 7m/s up to 500m/s
Light source	Laser diode 620-690 nm (red) Beam divergence: 0.16 x 0.6 mrad IEC 60825-1:2007; Class 2 Pulse duration: 0.45x10 ⁻⁹ s FDA 21CFR 1040.10 and 1040.11 Maximum radiant power: 0.95 mW
Laser Life Time	typical 50'000h @ 20°C (See 4.1.4 Laser Life time consideration on page 17)
ESD	IEC 61000-4-2
EMC	EN 61000-6-4 EN 61000-6-2
Power supply	9 ... 30V DC 0.6A for DLS-C / FLS-C 24 ... 30V DC 2.5A for DLS-CH /FLS-CH(Heating option)
Dimensions	150 x 80 x 55 mm
Temperature range during operation ²⁾ DLS-C 15 / DLS-C 30 DLS-CH 15 / DLS-CH 30	-10 °C to +50 °C -40 °C to +50 °C
Temperature range during storage	-40 °C to +70 °C
Degree of Protection	IP65; IEC60529 (protected against ingress of dust and water)
Weight	DLS-C, FLS-C: 690 g DLS-CH, FLS-CH: 720 g
Standard interface	1 serial asynchronous interface RS-232 1 serial asynchronous interface RS-422 1 SSI (only FLS-C(H)) 1 programmable analog output 0/4 .. 20mA 2 programmable digital outputs 1 programmable digital input 1 digital output for error status

1) See 5.1 Measuring accuracy on page 20.

2) In case of permanent continuous measurement (tracking mode) the max. temperature is reduced to 45°C

3) Accuracy and measurement speed depend on configuration (See 9.3.2 Measuring characteristic configuration (sNuc) on page 33)

4) By measuring on the orange reflecting target plate the accuracy may be reduced to $\pm 1.5 \text{ mm @ } 2\sigma$

6 Electrical components

6.1 ID switch

This switch is used to set the Device ID and can be set from 0 to 9. The default setting is 0.

6.2 Reset switch

To reset the device to factory settings do the following:

- Change ID Switch to position 0
- Switch OFF the power for the device
- Press the reset button and keep it pressed
- Switch on the power for the device
- Keep the reset button pressed until all LEDs on the device are illuminated
- Release the reset button
- Switch the power OFF and wait 5 seconds
- Switch on the power and wait until the green power LED is on

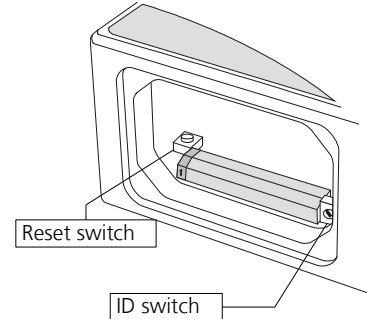

6.3 Digital output

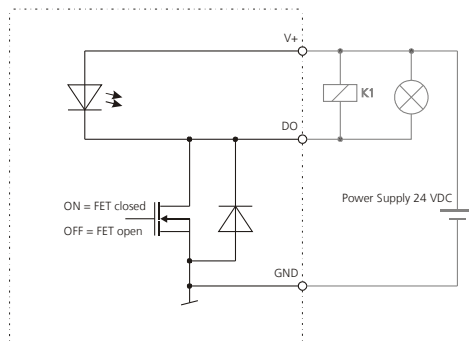

Fig. 20: Open drain output with external load

The DLS-C(H)/FLS-C(H) contain two digital outputs for level monitoring (DO 1 and DO 2) and one digital output for error signalization (DO E). These outputs are open drain outputs as shown in figure Fehler: Referenz nicht gefunden and can drive up to **200mA**. Maximum switching voltage is 30V DC. In the ON state, the FET transistor is electro conductive.

6.4 Digital input

The Digital Output (DO 1) can be configured as a Digital Input (DI 1). This is useful for triggering measurements by means of an external switch or push button. Please refer to chapter 4.2.7 External trigger connection on page 19.

- Low Level is: $U_{DI1} < 2VDC$
 High Level is: $U_{DI1} > 9VDC$ and $U_{DI1} < 30VDC$

6.5 Analog output

The analog output of the DLS-C(H)/FLS-C(H) is a current source (0..20mA or 4..20mA). It is capable of driving loads up to 500 Ω.

$$e_{Dist} = Accuracy_{Device} + \frac{(MaxDist_{Conf} - MinDist_{Conf}) * Accuracy_{AO}}{100}$$

e_{Dist} Total error in mm
 $Accuracy_{Gerät}$ Device accuracy in mm
 $Accuracy_{AO}$ Accuracy of the analog output in %
 $MaxDist_{Conf}$ Configured max Distance in mm
 $MinDist_{Conf}$ Configured min Distance in mm

Example:	DLS-C(H) 30
Device accuracy	±3 mm
Min. Distance	0 mm
Max. Distance	10'000 mm
Accuracy analog output FLS	±0.1%
Total error	$3mm + \frac{(10000-0)*0.1}{100} = \pm 13mm$

 The stated errors include all possible errors as Temperature drift, linearity, surface color and measurement distance.



The best accuracy of ±1.5 mm for the DLS-C(H) 15 and ±1 mm for the FLS-C(H) 10 can only be achieved by using the digital interfaces (RS-232, RS-422 or SSI)

6.6 RS-232 serial interfaces

The RS-232 interface is used for device configuration. It is made to connect the sensor to a PC to do the configuration either by terminal program or by the UtilitySW (See 3.1 Connection for configuration on page 8).



If the Moving Target measurement characteristic is active, a measurement speed of 250Hz is only possible if the baud rate is set to 115200. Lower baud rates reduce the measurement speed

6.7 RS-422 serial interface

The RS-422 interface is made for industrial communication and therefore long cables (twisted pair) are supported. This interface is thought to use the DLS-C(H)/FLS-C(H) in controlled mode.



The RS-422 interface cannot be used simultaneous with the SSI interface.



If the Moving Target measurement characteristic is active, a measurement speed of 250Hz is only possible if the baud rate is set to 115200. Lower baud rates reduce the measurement speed

6.8 SSI output



The SSI Interface is implemented in the FLS-C(H) only.

6.8.1 SSI Specification

SSI parameters	Setting for FLS-C(H)
Distance output values	0.. 16777215 1/10mm (max. 1.67km)
Measurement value coding	Binary or gray, MSB first
Transmission mode	Configurable, 23/24-bit measurement value, error bit, error code
Resolution	0.1mm
Read out rate	≤ 200Hz
SSI clock rate from controller	83KHz to 1MHz, depending of cable length.
Time lag between two data packets, pause time t_p	> 1ms
Monoflop time, t_m	25μs
Electrical levels, line driver	RS-422/485
Cable connection	Twisted pair, shielded

6.8.2 SSI Timing

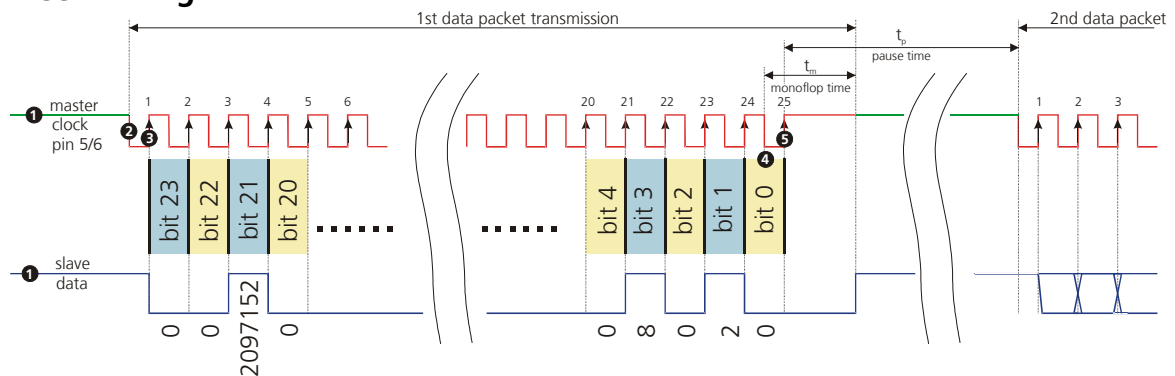

Fig. 21: Timing diagram SSI

- t_m Monoflop Time: Minimum time to detect the end of transmission. After t_m , the data line goes to idle state and the slave starts updating the internal value for the next transmission.
- t_p Pause time: Pause time between two consecutive clock sequences of the master.

The SSI is initially in the idle mode, where the data and clock lines stay HIGH ① and the slave keeps updating its internal value. The transmission mode is evoked when the master initiates a sequence by pulling the clock line to low. Once, the slave receives the resulting falling edge ② at the clock signal line, it automatically stops updating its internal value. With the first rising edge ③ of the clock line, the MSB of the sensor's value is transmitted and with consequent rising edges, the data bits are sequentially transmitted. After the transmission of the complete data word ④ (e.g. LSB is transmitted) an additional last rising edge ⑤ of the clock sets the clock line to HIGH. The slave sets or leaves the data line to low and remains there for the time t_m , to recognize the transfer timeout. If a falling edge of the clock signal (data-output request) is received within the time t_m , the same data as before will be transmitted again (multiple transmission).

If there were no clock pulses within time t_m , the slave starts updating its internal value after setting the data line to HIGH (idle mode). This marks the end of a single transmission of a data word. Once the slave receives a clock signal at a time, t_p ($\geq t_m$) the updated position value is frozen and the transmission of the new value begins as described earlier.

6.9 Connector

6.9.1 D-Sub connector



Pin	Designator	Description
1	Rx	RS-232 receive line
2	Tx	RS-232 send line
3	T-	RS-422 send line negative SSI data output negative (for FLS-C(H) if configured for SSI)
4	T+	RS-422 send line positive SSI data output positive (for FLS-C(H) if configured for SSI)
5	R-	RS-422 receive line negative SSI clock input negative (for FLS-C(H) if configured for SSI)
6	R+	RS-422 receive line positive SSI clock input positive (for FLS-C(H) if configured for SSI)
7	V+	DC Power
8	V+	+ 9V...+30V for DLS-C / FLS-C +24V...+30V for DLS-CH / FLS-CH (Heating option)
9	DO 1	Digital output 1 (Open Drain) or Digital input 1
10	DO 2	Digital output 2 (Open Drain)
11	DO E	Digital output for error signalization (Open Drain)
12	AGND	Analog ground
13	AO	Analog output (0/4..20mA)
14	GND	Ground line
15	GND	Ground line

6.9.2 Screw terminal

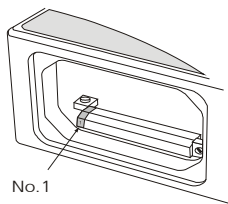

Designator	Description
R+	RS-422 send line negative SSI data output negative (for FLS-C(H) if configured for SSI)
R-	RS-422 send line positive SSI data output positive (for FLS-C(H) if configured for SSI)
T+	RS-422 receive line negative SSI clock input negative (for FLS-C(H) if configured for SSI)
T-	RS-422 receive line positive SSI clock input positive (for FLS-C(H) if configured for SSI)
Tx	RS-232 Transmit line
Rx	RS-232 Receive line
AGND	Analog ground
AO	Analog output (0/4..20mA)
DO E	Digital output for error signalization (Open Drain)
DO 2	Digital output 2 (Open Drain)
DO 1	Digital output 1 (Open Drain) or Digital input 1
GND	Ground line
V+	Power DC +9V...+30V DLS-C / FLS-C +24...+30V DLS-CH / FLS-CH (Heating option)

7 Physical dimensions

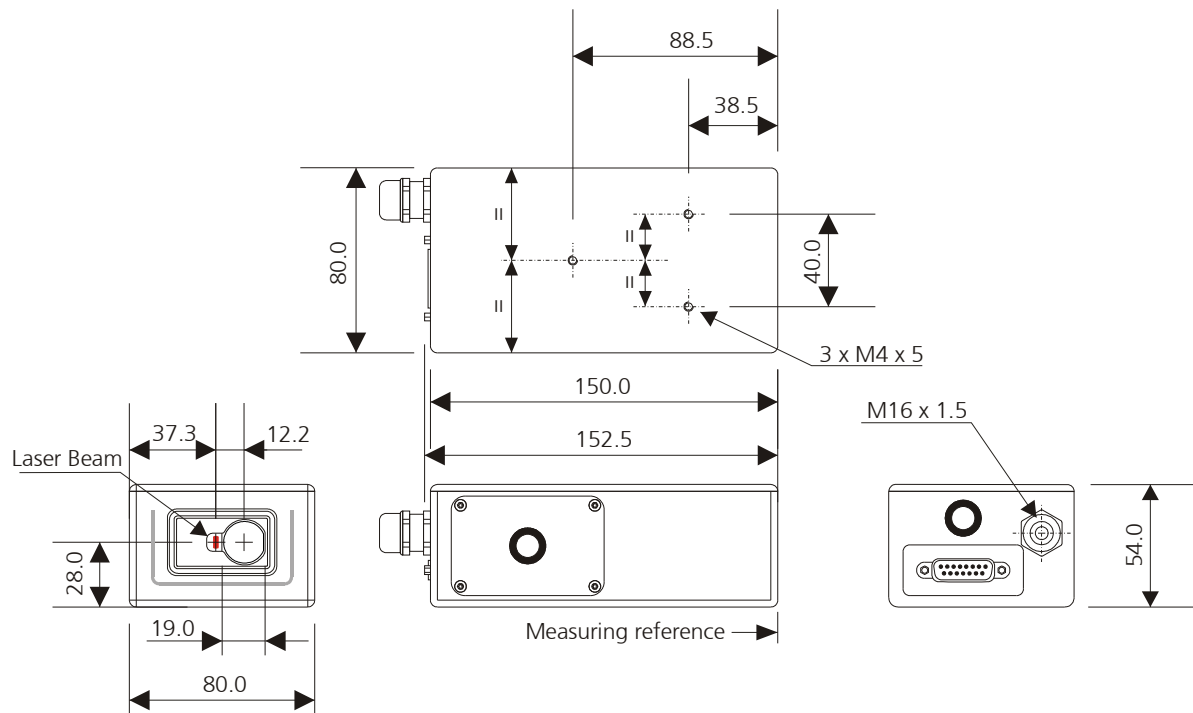

All dimensions in mm

8 Factory settings

8.1 Standard configuration

Operation Mode	Controlled
Serial Communication	Setting 7 Baud: 19200 Parity: Even Data bit: 7 Stop bit: 1
Analog outputs	Min output: 4mA Range min: 0m Error output: 0mA Range max: 10m
SSI Output	Inactive (default is RS-422 active) Replacement value in case of an error: 0
Device ID	ID Number: 0
Digital output 1 (DOUT1)	ON: 2m + 5mm = 2005mm OFF: 2m - 5mm = 1995mm
Digital output 2 (DOUT2)	ON: 1m - 5mm = 995mm OFF: 1m + 5mm = 1005mm
Digital input 1 (DI1)	Inactive, configured as output

8.2 User configured measurement

User distance offset and gain	User distance offset = 0mm User Gain Num = $\text{Gain} = \frac{\text{GainNum}_{\text{User}}}{\text{GainDen}_{\text{User}}} = \frac{1000}{1000} = 1$ 1000 User Gain Den = 1000 1000
Measurement characteristic	Normal
Measurement Filter	inactive
Output protocol	No special configuration, display distance

9 Command set

9.1 General

9.1.1 Command termination <trm>

All commands for the DLS-C(H)/FLS-C(H) are ASCII based and terminated <trm> with <cr><lf>.

9.1.2 Device identification *N*

Since the device can be addressed with the ID switch, the ID is represented in the commands by *N*.
At the location of the *N* insert the Device ID.

9.1.3 Parameter separator

The command syntax uses the '+' sign as parameter separator. The '+' sign can be replaced by the minus '-' sign if applicable by the command.

9.1.4 Set/Get commands

All configuration commands that are used to set configuration values can also be used to read the currently set value by omitting the parameter. The command syntax is described as follows:

	Set command	Get command
Command	s <i>N</i> uof+xxxxxxxx<trm>	s <i>N</i> uof<trm>
Return successful	g <i>N</i> uof?<trm>	g <i>N</i> uof+xxxxxxxx<trm>
Return error	g <i>N</i> @Ezzz<trm>	g <i>N</i> @Ezzz<trm>
Parameters	<i>N</i> Device ID xxxxxxxx Offset in 1/10 mm; + positive / - negative zzz Error code	

9.1.5 Startup sequence

After power on, the DLS-C(H)/FLS-C(H) does all the initializations and sends a start sequence g*N*?. On this sequence, the *N* stands for the Device ID. After sending this start sequence, the DLS-C(H)/FLS-C(H) is ready to use.

9.2 Operation commands

9.2.1 Distance measurement (sNg)

Triggers simple measurement of distance. Each new command cancels an active measurement.

	Command	
Command	sNg<trm>	
Return successful	gNg+xxxxxxxx<trm>	
Return error	gN@Ezzz<trm>	
Parameters	N	Device ID
	xxxxxxxx	Distance in 1/10 mm
	zzz	Error code

9.2.2 Single sensor tracking (sNh)

Triggers continuous measurements of the distance. The measurements are made as fast as possible (Measurement speed depends on target conditions). This command is not to be used with more than one DLS-C(H)/FLS-C(H) on a RS-232/RS-422 line. The measurements are continued until the STOP/CLEAR command is issued. The status LEDs and the digital outputs are updated corresponding to the new measured distance.



Never use this command if more than one module is connected to the RS-232/RS-422 line

	Command	
Command	sNh<trm>	
Return successful	gNh+xxxxxxxx<trm>	
Return error	gN@Ezzz<trm>	
Parameters	N	Device ID
	xxxxxxxx	Distance in 0.1mm
	zzz	Error code

9.2.3 Single sensor tracking with timer(sNh)

This command does the same as the sNf command, but the unit sends the results directly to the output.



Never use this command if more than one device is connected to the RS-422 line

	Command	
Command	sNh+xxx<trm>	
Return successful	gNh+yyyyyyyy<trm>	
Return error	gN@Ezzz<trm>	
Parameters	N	Device ID
	xxx	Sampling time in 10ms (if 0 -> use max. possible sample rate)
	yyyyyyyy	Distance in 0.1mm
	zzz	Error code

9.2.4 Tracking with buffering – Start (sNf)

Triggers continuous measurements of the distance with internal buffering in the device (buffer for one measurement). The rate of measurements is defined with the sampling time. If the sampling time is set to zero, the measurements are executed as fast as possible (Measuring speed depends on target conditions). The last measurement can be read out from the module with the command `sNq`. The measurements are continued until the 'sNc' command is issued.

	Set command	Get command
Command	<code>sNf+xxxxxxxx<trm></code>	<code>sNf<trm></code>
Return successful	<code>gNf?<trm></code>	<code>gNf+xxxxxxxx<trm></code>
Return error	<code>gN@Ezzz<trm></code>	<code>gN@Ezzz<trm></code>
Parameters	<p>N Device ID</p> <p>xxxxxxx Sampling time in 10ms (if 0 -> max possible rate)</p> <p>zzz Error code</p>	

9.2.5 Read out - Tracking with buffering(sNq)

After starting "tracking with buffering" with the command `sNf`, the latest measurement can be read out from the module with the command `sNq`. This command does not work if the tracking with buffering is not started.

	Command	
Command	<code>sNq<trm></code>	
Return successful	<code>gNq+xxxxxxxx+c<trm></code>	
Return error	<code>gN@Ezzz+c<trm></code>	
Parameters	<p>N Device ID</p> <p>xxxxxxxx Distance in 0.1mm</p> <p>c 0 = no new measurement since last sNq command 1 = one new measurement since last sNq command, not overwritten 2 = more than one measurement since last sNq command, overwritten</p> <p>zzz Error code</p>	

9.2.6 STOP/CLEAR command (sNc)

Stops the current execution and resets the status LEDs as well as the digital outputs.

	Command	
Command	<code>sNc<trm></code>	
Return successful	<code>gN?<trm></code>	
Return error	<code>gN@Ezzz<trm></code>	
Parameters	<p>N Device ID</p> <p>zzz Error code</p>	

9.2.7 Signal measurement (sNm)

Signal measurement can be done continuously or with a single measurement. The signal strength is returned as a relative number in the typical range of 0 to 40 millions.

The value for the signal strength is just an approximate value, it differs from device to device and also depends on environment conditions.

	Command	
Command	<code>sNm+c<trm></code>	
Return successful	<code>gNm+xxxxxxxx<trm></code>	
Return error	<code>gN@Ezzz<trm></code>	
Parameters	<p>N Device ID</p> <p>c 0: single measurement 1: repetitive measurements ! warning: use with one sensor only</p> <p>xxxxxxxx Signal strength (range 0.. 40 millions)</p> <p>zzz Error code</p>	

9.2.8 Temperature measurement (sNt)

Triggers measurement of the temperature inside the sensor.

	Command	
Command	sNt<trm>	
Return successful	gNt+xxxxxxxx<trm>	
Return error	gN@Ezzz<trm>	
Parameters	N	Device ID
	xxxxxxxx	Temperature in 0.1°C
	zzz	Error code

9.2.9 Laser ON (sNo)

Switches the laser beam ON for easy adjustment.

	Command	
Command	sNo<trm>	
Return successful	gN?<trm>	
Return error	gN@Ezzz<trm>	
Parameters	N	Device ID
	zzz	Error code

9.2.10 Laser OFF (sNp)

Switches the laser OFF.

	Command	
Command	sNp<trm>	
Return successful	gN?<trm>	
Return error	gN@Ezzz<trm>	
Parameters	N	Device ID
	zzz	Error code

9.3 Configuration commands

9.3.1 Set communication parameter (sMbr)

Sets the communication parameters for the serial interface.



**This command saves all configuration parameters to Flash.
The changed baud rate is activated after the next power on.**

Bold = default parameters (first use or after reset)

Command																																																									
Command	sMbr+y<trm>																																																								
Return successful	gN?<trm>																																																								
Return error	gN@Ezzz<trm>																																																								
Parameters	<p>N Device ID</p> <p>y Defines the new settings</p> <table border="1" style="margin-left: 40px;"> <thead> <tr> <th>%</th> <th>Baud rate</th> <th>Data bits</th> <th>Parity</th> <th>%</th> <th>Baud Rate</th> <th>Data bit</th> <th>Parity</th> </tr> </thead> <tbody> <tr> <td>0</td> <td>1200</td> <td>8</td> <td>N</td> <td>6</td> <td>9600</td> <td>7</td> <td>E</td> </tr> <tr> <td>1</td> <td>9600</td> <td>8</td> <td>N</td> <td>7</td> <td>19200</td> <td>7</td> <td>E</td> </tr> <tr> <td>2</td> <td>19200</td> <td>8</td> <td>N</td> <td>8</td> <td>38400</td> <td>8</td> <td>N</td> </tr> <tr> <td>3</td> <td>1200</td> <td>7</td> <td>E</td> <td>9</td> <td>38400</td> <td>7</td> <td>E</td> </tr> <tr> <td>4</td> <td>2400</td> <td>7</td> <td>E</td> <td>10</td> <td>115200</td> <td>8</td> <td>N</td> </tr> <tr> <td>5</td> <td>4800</td> <td>7</td> <td>E</td> <td>11</td> <td>115200</td> <td>7</td> <td>E</td> </tr> </tbody> </table>	%	Baud rate	Data bits	Parity	%	Baud Rate	Data bit	Parity	0	1200	8	N	6	9600	7	E	1	9600	8	N	7	19200	7	E	2	19200	8	N	8	38400	8	N	3	1200	7	E	9	38400	7	E	4	2400	7	E	10	115200	8	N	5	4800	7	E	11	115200	7	E
%	Baud rate	Data bits	Parity	%	Baud Rate	Data bit	Parity																																																		
0	1200	8	N	6	9600	7	E																																																		
1	9600	8	N	7	19200	7	E																																																		
2	19200	8	N	8	38400	8	N																																																		
3	1200	7	E	9	38400	7	E																																																		
4	2400	7	E	10	115200	8	N																																																		
5	4800	7	E	11	115200	7	E																																																		

9.3.2 Measuring characteristic configuration (sNuc)

Multiple measuring characteristic available in the FLS-C measuring devices meet different requirements for various applications. With these measuring characteristics measuring rate and accuracy can be optimized for special requirements.

While on factory settings, the FLS-C measuring device has an accuracy of ± 1 mm 2σ (FLS-C(H) 10) respectively ± 3 mm 2σ (FLS-C(H) 30). Measuring rate depends on environmental conditions such as target surface, distance, background light (e.g. sun light), etc. Good environmental conditions increase measuring rate (e.g. white target surface or orange reflective target plate and dark environment).

For a detailed description of the different measuring characteristics see 3.4 Measuring characteristics on page 12.



The configuration command sNuc is applied to the special user commands and to the standard commands.

	Set command	Get command
Command	sNuc+a+b<trm>	sNuc
Return successful	gNuc+xxxxxxxx+yyyyyyy<trm>	gNuc+xxxxxxxx+yyyyyyy<trm>
Return error	gN@Ezzz<trm>	gN@Ezzz<trm>
Parameters	<p><i>N</i> Device ID</p> <p><i>a</i> 0</p> <p><i>b</i> 0: Normal 1: Fast 2: Precise 3: Natural surface</p> <p><i>a</i> 1</p> <p><i>b</i> 1: Timed</p> <p><i>a</i> 2</p> <p><i>b</i> 0: Moving target characteristic with error freezing Every error will be preserved. For an error reset, the measurement must be restarted according to the configured operation mode. (See 3.4.3 Error behavior on page 14)</p> <p>1: Moving target characteristic without error freezing Distance jumps or unfavorable signal conditions may cause a temporary or permanent error.</p> <p><i>Temporary error</i> As soon as the FLS is able to determine a new distance value, the error will disappear and the output will show the new distance value. The shortest possible time to display an error is 4.5ms.</p> <p><i>Permanent error</i> The FLS is not able to determine a distance anymore. The error will be shown with an output rate of up to 250Hz. For an error reset, the measurement must be restarted according to the configured operation mode. (See 3.4.3 Error behavior on page 14)</p> <p><i>zzz</i> Error code</p>	

Configuration parameters need to be saved (See 9.3.13 Save configuration parameters (sNs) on page 39)

9.3.3 Set auto start configuration (sNA)

This command activates the stand-alone mode with auto start of the DLS-C(H)/FLS-C(H). It triggers continuous measurements of the distance. The analog, digital and SSI outputs are updated according to the measured distance values. The sampling time defines the measurement rate. If the sampling time is set to zero, the measurements are executed as fast as possible (depending on target conditions).

The stand-alone mode with auto start is active until the STOP/CLEAR command (sNc) is received by the device.



The operating mode is stored in the DLS-C(H)/FLS-C(H) and activated immediately. This mode is also activated after next power ON.



Internally, "tracking with buffering" is started (command sNf). Therefore, the latest measurement can also be read out from the module with the command sNq.

	Command	
Command	sNA+xxxxxxxx<trm>	
Return successful	gNA?<trm>	
Return error	gN@Ezzz<trm>	
Parameters	N Device ID xxxxxxxx Sampling time in 10 ms (if 0 -> max. possible rate) zzz Error code	

9.3.4 Set/Get analog output min level (sNvm)

This command sets the minimum analog output current level (0 or 4 mA).

	Set command	Get command
Command	sNvm+x<trm>	sNvm<trm>
Return successful	gNvm?<trm>	gNvm+x<trm>
Return error	gN@Ezzz<trm>	gN@Ezzz<trm>
Parameters	N Device ID x Minimum output for analog out 0: Minimum current is 0 mA 1: Minimum current is 4 mA zzz Error code	

Configuration parameters need to be saved (See 9.3.13 Save configuration parameters (sNs) on page 39)

9.3.5 Set/Get analog output value in error case (sNve)

This command sets the analog output current level in mA in case of an error. This level can be lower than the minimum level set in 9.3.4 Set/Get analog output min level (sNvm).

	Set command	Get command
Command	sNve+xxx<trm>	sNve<trm>
Return successful	gNve?<trm>	sNve+xxx<<trm>
Return error	gN@Ezzz<trm>	gN@Ezzz<trm>
Parameters	N Device ID xxx Value in case of an error in 0.1mA If the value is set to 999, in case of an error keep the last valid distance zzz Error code	

Configuration parameters need to be saved (See 9.3.13 Save configuration parameters (sNs) on page 39)

9.3.6 Set/Get analog output distance range (sNv)

Sets the minimum and maximum distances corresponding to the minimum and maximum analog output current levels.

0...20mA	4...20mA
$A_{out} = \frac{DIST - D_{min}}{D_{max} - D_{min}} * 20mA$	$A_{out} = \frac{DIST - D_{min}}{D_{max} - D_{min}} * 16mA + 4mA$
<i>Aout</i>	Analog current output
<i>DIST</i>	Actual measured distance
<i>Dmin</i>	Distance programmed for the minimum output current
<i>Dmax</i>	Distance programmed for the maximum output current

	Set command	Get command								
Command	sNv+xxxxxxxx+yyyyyyyyy<trm>	sNv<trm>								
Return successful	gNv?<trm>	gNv+xxxxxxxx+yyyyyyyyy<trm>								
Return error	gN@Ezzz<trm>	gN@Ezzz<trm>								
Parameters	<table style="width: 100%; border: none;"> <tr> <td style="width: 10%;"><i>N</i></td> <td>Device ID</td> </tr> <tr> <td><i>xxxxxxxx</i></td> <td>Minimum distance in 1/10 mm corresponding to 0mA / 4mA</td> </tr> <tr> <td><i>yyyyyyyy</i></td> <td>Maximum distance in 1/10 mm corresponding to 20mA</td> </tr> <tr> <td><i>zzz</i></td> <td>Error code</td> </tr> </table>		<i>N</i>	Device ID	<i>xxxxxxxx</i>	Minimum distance in 1/10 mm corresponding to 0mA / 4mA	<i>yyyyyyyy</i>	Maximum distance in 1/10 mm corresponding to 20mA	<i>zzz</i>	Error code
<i>N</i>	Device ID									
<i>xxxxxxxx</i>	Minimum distance in 1/10 mm corresponding to 0mA / 4mA									
<i>yyyyyyyy</i>	Maximum distance in 1/10 mm corresponding to 20mA									
<i>zzz</i>	Error code									

Configuration parameters need to be saved (See 9.3.13 Save configuration parameters (sNs) on page 39)

9.3.7 Set/Get digital output levels (sNn)

Sets the distance levels at which the digital outputs are switched ON and OFF with a hysteresis.

Two different situations are possible:

ON level > OFF level

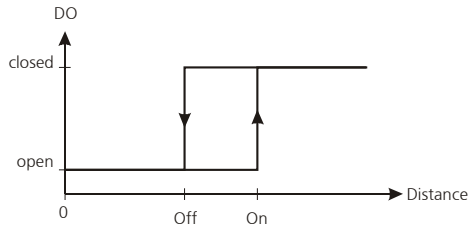

The ON level of the hysteresis is larger than the OFF level. With an increasing distance, the digital output is switched on (open drain output is closed) when the distance exceeds the ON level. With a decreasing distance, the digital output is switched off (open drain output is open) when the distance falls below the OFF level.

ON level < OFF level

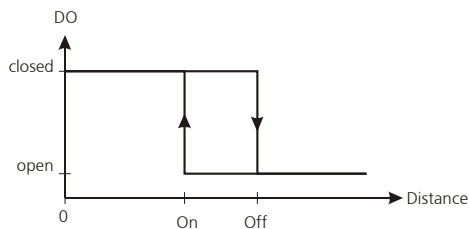

The ON level of the hysteresis is smaller than the OFF level. With a decreasing distance, the digital output is switched on (open drain output is closed) when the distance falls below the ON level. With an increasing distance, the digital output is switched off (open drain output is open) when the distance exceeds the OFF level.

	Set command	Get command
Command	sNn+xxxxxxxx+yyyyyyyyy<trm>	sNn<trm>
Return successful	gNn?<trm>	gNn+xxxxxxxx+yyyyyyyyy<trm>
Return error	gN@Ezzz<trm>	gN@Ezzz<trm>
Parameters	<i>N</i> Device ID <i>n</i> Digital output port (1 or 2) <i>xxxxxxxx</i> Distance ON level in 1/10 mm for switching digital output ON <i>yyyyyyyyy</i> Distance OFF level in 1/10 mm for switching digital output OFF <i>zzz</i> Error code	

Configuration parameters need to be saved (See 9.3.13 Save configuration parameters (sNs) on page 39)

9.3.8 Configure digital input (sNDI1)

The digital output 1 of the DLS-C(H)/FLS-C(H) can also be used as digital input. The command `sNDI1` configures an action for the device. The state of the digital input can be read with the command `sNRI`.



On active digital input, the digital output function of DO1 is deactivated

	Set command	Get command
Command	<code>sNDI1+xxxxxxxx<trm></code>	<code>sNDI1<trm></code>
Return successful	<code>gNDI1?<trm></code>	<code>sNDI1+xxxxxxxx<trm></code>
Return error	<code>gN@Ezzz<trm></code>	<code>gN@Ezzz<trm></code>
Parameters	<p><i>N</i> Device ID</p> <p><i>xxxxxxxx</i> 0: Digital input inactive (DO1 active) 1: activate the digital input to read out its state with the command <i>9.3.9 Read digital input (sNRI)</i>. 2: Trigger Distance measurement (sNg) 3: Start/Stop Single sensor Tracking (sNh) 4: Start/Stop Tracking with buffering (sNf) 5: Trigger User Distance measurement (sNug) 6: Start/Stop Single sensor User Tracking (sNuh) 7: Start/Stop User Tracking with buffering (sNuf) 8: Start/Stop Single sensor Timed Tracking (sNh+)¹⁾ 9: Start/Stop Single sensor User Timed Tracking (sNuh+)¹⁾</p> <p><i>zzz</i> Error code</p>	

1) Uses time for the tracking as set by a previous `sNh+` or `sNuh+` command

Configuration parameters need to be saved (See 9.3.13 Save configuration parameters (sNs) on page 39)

9.3.9 Read digital input (sNRI)

Displays the state of the digital input, if the input is not inactive. (Necessary configuration of the digital input: `sNDI1+1`)

	Command	
Command	<code>sNRI<trm></code>	
Return successful	<code>gNRI+x<trm></code>	
Return error	<code>gN@Ezzz<trm></code>	
Parameters	<p><i>N</i> Device ID</p> <p><i>x</i> 0: Input Off (Signal Low) 1: Input On (Signal High)</p> <p><i>zzz</i> Error code</p>	

9.3.10 Interface 2 configuration (RS-422 / SSI)

The SSI interface is implemented on the FLS-C(H) device only and deactivated by default. Since the SSI interface uses the same connection as the RS-422 interface only one of these two interface can be used at the same time.



Use the stand-alone mode with auto start to automatically update the SSI output value. (9.3.3 Set auto start configuration (sNA) page 34)

Connect the device by RS-232 to do the configuration and use the following commands to activate the SSI interface. See also 4.2.6 SSI connection on page 19 and 6.8 SSI output on page 25.

	Set command	Get command
Command	sNSSI+xxx<trm>	sNSSI<trm>
Return successful	gNSSI?<trm>	gNSSI+xxx<trm>
Return error	gN@Ezzz<trm>	gN@Ezzz<trm>
Parameters	<p><i>N</i> Device ID</p> <p><i>xxx</i> binary coded:</p> <p>Bit0 0: Interface 2 (IF2) functions as RS-422 (SSI is deactivated)</p> <p>1: Interface 2 (IF2) functions as SSI (RS-422 is deactivated)</p> <p>Bit1 0: Binary coded data output</p> <p>1: Gray coded data output</p> <p>Bit2 0: no error bit output</p> <p>1: error bit attached to the output data value</p> <p>Bit3 0: no additional error code output</p> <p>1: attach 8bit error code (Code -200)</p> <p>Bit4 0: 24 bit data value</p> <p>1: 23 bit data value</p> <p><i>zzz</i> Error code</p>	

Configuration parameters need to be saved (See 9.3.13 Save configuration parameters (sNs) on page 39)

9.3.10.1 Configuration examples

24 Bit data, Error code and Error bit

Data (24 Bit binary)														Error code (binary)								Error bit														
MSB	23	22	21	20	19	18	17	16	15	14	13	12	11	10	9	8	7	6	5	4	3	2	1	0	LSB	MSB	7	6	5	4	3	2	1	0	LSB	0

Configuration: 01101 → 13

Bit0 = 1: Interface 2 (IF2) functions as SSI (RS-422 is deactivated) Bit2 = 1: Error bit attached to the output data value

Bit1 = 0: Binary coded data output Bit3 = 1: Attach 8 bit error code (Code -200)

Bit4 = 0: 24 bit data value

Command: sNSSI+13

23 Bit data and Error bit

Data (23 Bit gray)														Error bit											
MSB	22	21	20	19	18	17	16	15	14	13	12	11	10	9	8	7	6	5	4	3	2	1	0	LSB	0

Configuration: 10111 → 23

Bit0 = 1: Interface 2 (IF2) functions as SSI (RS-422 is deactivated) Bit2 = 1: Error bit attached to the output data value

Bit1 = 1: Gray coded data output Bit3 = 0: No additional error code output

Bit4 = 1: 23 bit data value

Command: sNSSI+23

24 Bit data

Data (24 Bit binary)																									
MSB	23	22	21	20	19	18	17	16	15	14	13	12	11	10	9	8	7	6	5	4	3	2	1	0	LSB

Configuration: 00001 → 1

Bit0 = 1: Interface 2 (IF2) functions as SSI (RS-422 is deactivated) Bit2 = 0: No error bit output

Bit1 = 0: Binary coded data output Bit3 = 0: No additional error code output

Bit4 = 0: 24 bit data value

Command: sNSSI+1

9.3.11 Set/Get error value on SSI output

In case of an error the SSI output will show a value corresponding to this configuration. There can be a replacement value in a range of 0 to 16777215 (24Bit) or 0 to 8388607 (23Bit), the last valid distance value or the error code.

All values are shown either as binary value or gray coded depending on configuration.

	Set command	Get command
Command	sNSSIe+xxxxxxx<trm>	sNSSIe<trm>
Return successful	gNSSIe?<trm>	gNSSIe+xxxxxxx<trm>
Return error	gN@Ezzz<trm>	gN@Ezzz<trm>
Parameters	<i>N</i> Device ID xxxxxxxx 0..2 ²⁴ -1 / 0..2 ²³ -1: -1: -2: zzz Error code	Replacement value In case of an error, the data value will be replaced by this replacement value. (depending on the settings, the value will be converted to gray code): in case of an error the last distance value will stay at the output. in case of an error the error code will be at the output (converted to gray code if configured)

Configuration parameters need to be saved (See 9.3.13 Save configuration parameters (sNs) on page 39)

9.3.12 Set/Get measurement filter configuration (sNfi)

The filter applied to the measurement value can be configured according the following command

	Set command	Get command
Command	sNfi+aa+bb+cc<trm>	sNfi<trm>
Return successful	gNfi?<trm>	gNfi+aa+bb+cc<trm>
Return error	gN@Ezzz<trm>	gN@Ezzz<trm>
Parameters	<i>N</i> Device ID aa Filter length (0: Filter off, 32: max value) bb Number of spikes to suppress (always pairs of min and max value) cc max number of errors to suppress. Condition: 2*bb+cc <= 0.4*aa zzz Error code	

See 3.6 Output value filter on page 16 for additional information.

9.3.13 Save configuration parameters (sNs)

This command saves all configuration parameters, which are set by the commands above. The parameters are written to the Flash Memory.

	Command	
Command	sNs<trm>	
Return successful	gNs?<trm>	
Return error	gN@Ezzz<trm>	
Parameters	<i>N</i> Device ID zzz Error code	

9.3.14 Set configuration parameters to factory default (sNd)

This command restores all configuration parameters to their factory default values. The parameters are written to the Flash Memory and therefore permanently saved.



The communication parameters are also reset to factory settings.

	Command	
Command	sNd<trm>	
Return successful	gN?<trm>	
Return error	gN@Ezzz<trm>	
Parameters	N	Device ID
	zzz	Error code

9.3.15 Get software version (sNsv)

Retrieves the software version of the DLS-C(H)/FLS-C(H).

	Command	
Command	sNsv<trm>	
Return successful	gNsv+xxxxyyyy<trm>	
Return error	gN@Ezzz<trm>	
Parameters	N	Device ID
	xxxx	Internal measuring module software version number
	yyyy	Interface software version
	zzz	Error code

9.3.16 Get serial number (sNsn)

Retrieves the serial number of the DLS-C(H)/FLS-C(H).

	Command	
Command	sNsn<trm>	
Return successful	gNsn+xxxxxxxx<trm>	
Return error	gN@Ezzz<trm>	
Parameters	N	Device ID
	xxxxxxxx	Serial number of the device
	zzz	Error code

9.3.17 Get device generation and type (dg)

This command returns the device type, generation and current communication settings.

Works only from device generation C on.

	Command	
Command	dg	
Return successful	gNdg+xxx+yz?<trm>	
Return error	gN@Ezzz	
Parameters	N	Device ID
	xxx	Bit coded number to identify the device: 0x53 (83) DLS-C / FLS-C
	y	(additional internal information)
	z	Communication settings (see command sNbr+C)
	zzz	Error code

9.3.18 Get device type (dt)

This command returns the device type.

	Command	
Command	dt	
Return successful	gNdt+xyy<term>	
Return error	gN@Ezzz	
Parameters	<i>N</i> Device ID <i>x</i> Generation shown as a number. <i>yy</i> Device number. Output for <i>xyy</i> 301: DLS-C(H) 302: FLS-C(H) <i>zzz</i> Error code	

9.4 Special user operation commands

The special user commands are user configurable and are an extension to the standard commands. Use these commands carefully and only if you really understand their impact.

The syntax of the user commands differ to the standard commands as follows:

Standard Commands: `sNx`
 User Commands: `sNux`

The user configuration parameters influence the result of the user commands. A gain and offset may be applied to the measurement result and the output format may be configured.

9.4.1 User distance measurement (sNug)

Triggers simple distance measurement, similar to the command 9.2.1 Distance measurement (sNg) on page 29. This command returns the distance corrected with the user offset and user gain as set with the commands 9.5.2 Set/Get user distance offset (sNuof) and 9.5.3 Set/Get user distance gain (sNuga) on page 44.



This command takes the user distance offset and user gain into account

	Command	
Command	<code>sNug<trm></code>	
Return successful	<code>gNug+xxxxxxxx<trm></code>	
Return error	<code>gN@Ezzz<trm></code>	
Parameters	<i>N</i> Device ID xxxxxxxx Distance in 0.1mm zzz Error code	

9.4.2 User single sensor tracking (sNuh)

Triggers continuous measurement of the distance and outputs the result immediately to the serial interface. The distance measurement is executed as fast as possible (depending on target conditions). The measured distance is corrected with the user offset and user gain as set with the commands 9.5.2 Set/Get user distance offset (sNuof) and 9.5.3 Set/Get user distance gain (sNuga) on page 44. The measurements are continued until the STOP/CLEAR command (sNc) is received by the device.



This command takes the user distance offset into account



Never use these commands if more than one device is connected to the RS-422 line

	Command	
Command	<code>sNuh<trm></code>	
Return successful	<code>gNuh+xxxxxxxx<trm></code>	
Return error	<code>gN@Ezzz<trm></code>	
Parameters	<i>N</i> Device ID xxxxxxxx Distance in 0.1mm zzz Error code	

9.4.3 User single sensor tracking with timer(sNuh)

This command does the same as the sNuf command, but the unit sends the results directly to the output.



This command takes the user distance offset and user gain into account



Never use this command if more than one device is connected to the RS-422 line

Command									
Command	sNuh+xxx<trm>								
Return successful	gNuh+yyyyyyyyy<trm>								
Return error	gN@Ezzz<trm>								
Parameters	<table border="0"> <tr> <td>N</td> <td>Device ID</td> </tr> <tr> <td>xxx</td> <td>Sampling time in 10ms (if 0 -> use max. possible sample rate)</td> </tr> <tr> <td>yyyyyyyyy</td> <td>Distance in 0.1mm</td> </tr> <tr> <td>zzz</td> <td>Error code</td> </tr> </table>	N	Device ID	xxx	Sampling time in 10ms (if 0 -> use max. possible sample rate)	yyyyyyyyy	Distance in 0.1mm	zzz	Error code
N	Device ID								
xxx	Sampling time in 10ms (if 0 -> use max. possible sample rate)								
yyyyyyyyy	Distance in 0.1mm								
zzz	Error code								

9.4.4 User tracking with buffering – Start (sNuf)

Triggers continuous measurement of the distance with internal buffering in the device (buffer for one measurement). The measured distance is corrected with the user offset and user gain as set with the command 9.5.2 *Set/Get user distance offset (sNuof)* and 9.5.3 *Set/Get user distance gain (sNuga)* on page 44. Define the rate of measurements with the sampling time. If the sampling time is set to zero, the measurements are executed as fast as possible. The latest measurement can be read out from the device with the command sNuq. The measurements are continued until the stop/clear command (sNc) is issued.



This command takes the user distance offset and user gain into account

	Set command	Get command						
Command	sNuf+xxxxxxxx<trm>	sNuf<trm>						
Return successful	GNuf?<trm>	gNuf+xxxxxxxx<trm>						
Return error	gN@Ezzz<trm>	gN@Ezzz<trm>						
Parameters	<table border="0"> <tr> <td>N</td> <td>device ID</td> </tr> <tr> <td>xxxxxxxx</td> <td>Sampling time in 10ms (if 0 -> use max. possible sample rate)</td> </tr> <tr> <td>zzz</td> <td>Error code</td> </tr> </table>	N	device ID	xxxxxxxx	Sampling time in 10ms (if 0 -> use max. possible sample rate)	zzz	Error code	
N	device ID							
xxxxxxxx	Sampling time in 10ms (if 0 -> use max. possible sample rate)							
zzz	Error code							

9.4.5 Read out – User tracking with buffering (sNuq)

After starting "User-configured tracking with buffering" with the command sNuf, the latest measurement can be read out from the DLS-C(H)/FLS-C(H).



This command takes the user distance offset and user gain into account

Command									
Command	sNuq<trm>								
Return successful	gNuq+xxxxxxxx+c<trm>								
Return error	gN@Ezzz+c<trm>								
Parameters	<table border="0"> <tr> <td>N</td> <td>device ID</td> </tr> <tr> <td>xxxxxxxx</td> <td>Distance in 0.1mm</td> </tr> <tr> <td>c</td> <td>0 = no new measurement since last sNuq command 1 = one new measurement since last sNuq command, not overwritten 2 = more than one measurement since last sNuq command, overwritten</td> </tr> <tr> <td>zzz</td> <td>Error code</td> </tr> </table>	N	device ID	xxxxxxxx	Distance in 0.1mm	c	0 = no new measurement since last sNuq command 1 = one new measurement since last sNuq command, not overwritten 2 = more than one measurement since last sNuq command, overwritten	zzz	Error code
N	device ID								
xxxxxxxx	Distance in 0.1mm								
c	0 = no new measurement since last sNuq command 1 = one new measurement since last sNuq command, not overwritten 2 = more than one measurement since last sNuq command, overwritten								
zzz	Error code								

9.5 Special User configuration commands

9.5.1 Set user auto start configuration (sNuA)

This command activates the user stand-alone mode with auto start of the DLS-C(H)/FLS-C(H). It triggers continuous measurement of the distance. The distance output at the serial interface (RS-232 and RS-422) is corrected with the user offset and user gain as set with the command 9.5.2 Set/Get user distance offset (sNuof) and 9.5.3 Set/Get user distance gain (sNuga) on page 44. The analog, digital and SSI outputs are updated according to the measured distance values. The sampling time defines the measurement rate. If the sampling time is set to zero, the measurements are executed as fast as possible (depending on target conditions).

The user stand-alone mode with auto start is active until the STOP/CLEAR command (sNc) is received by the device.



The operating mode is stored in the DLS-C(H)/FLS-C(H) and activated immediately. This mode is also activated after next power ON.



Internally, "tracking with buffering" is started (command sNu£). Therefore, the latest measurement can also be read out from the module with the command sNuq.

	Command	
Command	sNuA+xxxxxxxx<trm>	
Return successful	gNuA?<trm>	
Return error	gN@Ezzz<trm>	
Parameters	N Device ID xxxxxxxx Sampling time in 10 ms (if 0 -> max. possible rate) zzz Error code	

9.5.2 Set/Get user distance offset (sNuof)

The user can set an individual overall offset correction for all distance measurement commands in this 'Special User Command' section. The standard distances measurement commands are not involved (See 3.5.1 Offset / Gain on page 15).

	Set command	Get command
Command	sNuof+xxxxxxxx<trm>	sNuof<trm>
Return successful	gNof?<trm>	gNuof+xxxxxxxx<trm>
Return error	gN@Ezzz<trm>	gN@Ezzz<trm>
Parameters	N Device ID xxxxxxxx Offset in 1/10 mm; + positive / - negative zzz Error code	

Configuration parameters need to be saved (See 9.3.13 Save configuration parameters (sNs) on page 39)

9.5.3 Set/Get user distance gain (sNuga)

The user can set an individual user gain to create user defined output values. The output value is calculated as follows (See 3.5.1 Offset / Gain on page 15).

	Set command	Get command
Command	sNuga+xxxxxxxx+yyyyyyyy<trm>	sNuga<trm>
Return successful	gNuga?<trm>	gNuga+xxxxxxxx+yyyyyyyy<trm>
Return error	gN@Ezzz	gN@Ezzz
Parameters	N Device ID xxxxxxxx GainNum _{User} yyyyyyyy GainDen _{User} GainDen _{User} Must not be zero zzz Error code	

Configuration parameters need to be saved (See 9.3.13 Save configuration parameters (sNs) on page 39)

9.5.4 User output protocol (sNuo)

This command modifies the output for the user configured commands. The output can be configured to fit the requirement of an external display.

A parameter for the output mode between 100 and 189 defines the format for an external display. The last digit of the parameter defines the field length for the output number. The output of a distance measurement will be right aligned. The decimal point will be inserted at the position (counted from right) defined by middle digit (See 3.5.2 Output format on page 15).

	Set command	Get command
Command	sNuo+xxxxxxxx<trm>	sNuo
Return successful	gNuo?<trm>	gNuo+xxxxxxxx<trm>
Return error	gN@Ezzz<trm>	gN@Ezzz<trm>
Parameters	<p><i>N</i> Device ID</p> <p><i>xxxxxxxx</i> Output Mode</p> <p>0: display distance</p> <p>1: display additional information</p> <p>1ab: output formatted for external display</p> <p>a: Number of digits after decimal point</p> <p>b: Field with (sign included) must be greater than 0</p> <p>Conditions: a≤b, if a=b, no decimal point is output.</p> <p><i>zzz</i> Error code</p>	

Configuration parameters need to be saved (See 9.3.13 Save configuration parameters (sNs) on page 39)

9.6 Error codes

No.	Format	Meaning and elimination
203	@E203	Wrong syntax in command, prohibited parameter in command entry or non-valid result
210	@E210	Not in tracking mode, start tracking mode first
211	@E211	Sampling too fast, set the sampling time to a larger value
212	@E212	Command cannot be executed, because tracking mode is active, first use command sNc to stop tracking mode
220	@E220	Communication error, check configuration settings
230	@E230	Distance value overflow caused by wrong user configuration. Change user offset (and/or user gain)
231	@E231	Wrong mode for digital input status read, activate DI1
232	@E232	Digital output 1 cannot be set if configured as digital input
233	@E233	Number cannot be displayed. (Check output format)
234	@E234	Distance out of range
236	@E236	Digital output manual mode cannot be activated when configured as digital input
252	@E252	Temperature too high (contact Dimetix if error occurs at room temperature)
253	@E253	Temperature too low (contact Dimetix if error occurs at room temperature)
254	@E254	Bad signal from target, It takes too long to measure according distance. Use white surface or reflective target.
255	@E255	Received signal too weak or target lost in moving target characteristic (Use different target and distances, if the problem persists, please contact Dimetix)
256	@E256	Received signal too strong (Use different target and distances, if the problem persists, please contact Dimetix)
258	@E258	Power supply voltage is too high
259	@E259	Power supply voltage is too low
260	@E260	Distance cannot be calculated because of ambiguous targets. Use clearly defined targets to measure the distance.
263	@E263	Too much light, use only Dimetix reflective target plate. In moving target characteristic, distance jump occurred
264	@E264	Too much light, measuring on reflective targets not possible
330	@E330	Acceleration of the target too strong or distance jump (in moving target characteristic only)
331	@E331	Over speed of target (in moving target characteristic only)
360	@E360	Configured measuring time is too short, set longer time or use 0
361	@E361	Configured measuring time is too long, set shorter time
not listed		Hardware failure (Contact Dimetix)

Before contacting Dimetix, please collect as much information as possible.

10 Safety instructions

The following instructions are to enable the person responsible for the DLS-C(H)/FLS-C(H), and the user of the instrument, to anticipate and avoid operational hazards.

The DLS-C(H)/FLS-C(H) is made to be integrated into technical systems. Basic technical training is therefore essential. This device may only be operated by trained personnel.

The person responsible for the instrument must ensure that all users understand these instructions and adhere to them.

If the DLS-C(H)/FLS-C(H) is part of a system, the manufacturer of such a system is responsible for all safety-related issues, such as the manual, labeling and instruction.

10.1 Use of the instrument

Permitted use:

The permitted use of the DLS-C(H)/FLS-C(H) is: measuring distances.

Prohibited use:

- 1) Use of the instrument without instruction
- 2) Use outside the stated limits
- 3) Deactivation of safety systems and removal of explanatory and hazard labels
- 4) Opening of the equipment, except to open the cover for access to the screw terminal
- 5) Carrying out modification or conversion of the product
- 6) Operation after failure in operation
- 7) Use of accessories from other manufacturers without the express approval of Dimetix
- 8) Aiming directly into the sun
- 9) Deliberate dazzling of third parties; also in the dark
- 10) Inadequate safeguards at the surveying location (e.g. when measuring on roads, etc.)

WARNING: Prohibited use can lead to injury, malfunction, and material damage. It is the duty of the person responsible for the instrument to inform the user about hazards and how to counteract them. The DLS-C(H)/FLS-C(H) must not be operated until the user has been adequately instructed.

10.2 Limits to use

☞ See 5 Technical data on page 20.

Environment:

Suitable for use in an atmosphere appropriate for permanent human habitation. The device must not be used in environments such as but not limited to:

- aggressive vapor or liquids
- snow and rain
- radiation (radioactive, heat, etc)
- explosive atmosphere

10.3 Areas of responsibility

Responsibilities of the manufacturer of the original equipment Dimetix AG, CH-9100 Herisau (Dimetix):

Dimetix is responsible for supplying the product, including the Technical Reference Manual and original accessories, in a completely safe condition.

Responsibilities of the manufacturer of non-Dimetix accessories:

The manufacturers of non-Dimetix accessories for the DLS-C(H)/FLS-C(H) are responsible for developing, implementing and communicating safety concepts for their products. They are also responsible for the effectiveness of these safety concepts in combination with the Dimetix equipment.

Responsibilities of the person in charge of the instrument:

WARNING: The person responsible for the instrument must ensure that the equipment is used in accordance with the instructions. This person is also accountable for the deployment of personnel and for their training and for the safety of the equipment when in use.

The person in charge of the instrument has the following duties:

- 1) To understand the safety instructions for the product and the instructions in the Technical Reference Manual.
- 2) To be familiar with local safety regulations relating to accident prevention.
- 3) To inform Dimetix immediately if the equipment becomes unsafe.

10.4 Hazards in use

WARNING: The absence of instruction, or the inadequate provision of instruction, can lead to incorrect or prohibited use, and can give rise to accidents with far-reaching personal, material and environmental consequences.

Precautions:

All users must follow the safety instructions given by the manufacturer and the directions of the person responsible for the instrument.

CAUTION: Beware of erroneous distance measurements if the instrument is defective or if it has been dropped or has been misused or modified.

Precautions:

Carry out periodic test measurements, particularly after the instrument has been subject to abnormal use, and before, during and after important measurements. Make sure the DLS-C(H)/FLS-C(H) optics are kept clean.

WARNING: If labels are hidden when the DLS-C(H)/FLS-C(H) is installed, this could lead to dangerous situations.

Precautions:

Always ensure the visibility of DLS-C(H)/FLS-C(H) labels at all times or add labels in accordance with the local safety regulations.

CAUTION: When using the instrument for distance measurements or for positioning moving objects (e.g. cranes, building equipment, platforms, etc.) unforeseen events (e.g. breaking the laser beam) may cause erroneous measurements.

Precautions:

Only use this product as a measuring sensor, not as a control device. The system must be configured and operated in such a way that no damage will occur in the event of an erroneous measurement, malfunction of the device or power failure due to installed safety measures (e.g. safety limit switch).

WARNING: Operate the equipment appropriately in accordance with the regulations in force. Always prevent access to the equipment by unauthorized personnel.

Precautions:

Do not point the telescope directly at the sun.

CAUTION: Be careful when pointing a telescope towards the sun, because the telescope functions as a magnifying glass and can injure eyes and/or cause damage inside the DLS-C(H)/FLS-C(H).

10.5 Laser classification

The DLS-C(H)/FLS-C(H) produces a visible laser beam, which emerges from the front of the instrument.

It is a Class 2 laser product in accordance with:

- IEC60825-1 (2007) "Radiation safety of laser products"
- EN60825-1 (2007) "Radiation safety of laser products"

It is a Class II laser product in accordance with:

- FDA 21CFR 1040.10 and 1040.11 (US Department of Health and Human Service, Code of Federal Regulations)

Laser Class 2/II products:

Do not stare into the laser beam or direct it towards other people unnecessarily. Eye protection is normally afforded by aversion responses including the blink reflex.

WARNING: Looking directly into the beam with optical aids (binoculars, telescopes) can be hazardous.

Precautions:

Do not look into the laser beam. Make sure the laser is aimed above or below eye level. (particularly with fixed installations, in machines, etc.).

CAUTION: Looking into the laser beam may be hazardous to the eyes.

10.6 Electromagnetic compatibility (EMC)

The term "electromagnetic compatibility" is taken to mean the capability of the DLS-C(H)/FLS-C(H) to function smoothly in an environment where electromagnetic radiation and electrostatic discharges are present, and without causing electromagnetic interference to other equipment.

WARNING: Electromagnetic radiation can cause interference in other equipment. Although the DLS-C(H)/FLS-C(H) meets the strict regulations and standards that are in force in this respect, Dimetix cannot completely exclude the possibility that interference may be caused to other equipment.

10.7 Producer Standards

Dimetix hereby certifies that the product has been tested and complies with the specifications as stated in this 'Technical Reference Manual'. The test equipment used is in compliance with national and international standards. This is established by our Quality Management System. Further, the DLS-C(H)/FLS-C(H) devices are produced in compliance with 2002/95/EG «RoHS».

10.8 Disposal



This symbol on the product or on its packaging indicates that this product must not be disposed of with your other household waste. Instead, it is your responsibility to dispose of the equipment by handing it over to a designated collection point for the recycling of waste electrical and electronic equipment. The separate collection and recycling of your waste equipment at the time of disposal will help to conserve natural resources and ensure that it is recycled in a manner that protects human health and the environment. For more information about where you can drop off your waste equipment for recycling, please contact your local city office, your household waste disposal service or the dealer where you purchased the product.

In countries in which Dimetix has no subsidiaries, Dimetix delegates the duty for the disposal in compliance with 2002/96/EG «WEEE» to the local dealer or to the customer, if no dealer is present.

10.9 Labeling

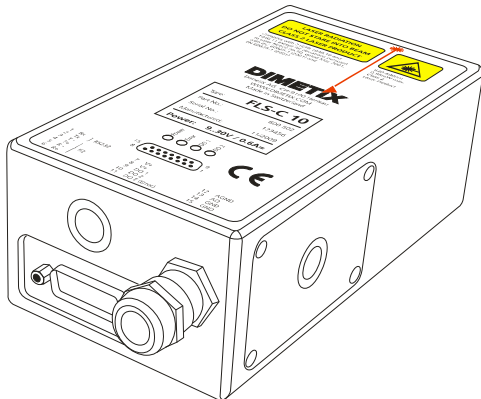

Fig. 22: Location of the label

Type: FLS-C 10 Part No.: 600 502 Serial No.: 123456 Manufactured: 11/2009 Power: 9..30V / 0.6A=	Type: FLS-C 30 Part No.: 600 501 Serial No.: 123456 Manufactured: 11/2009 Power: 9..30V / 0.6A=	Type: DLS-C 15 Part No.: 500 622 Serial No.: 123456 Manufactured: 11/2009 Power: 9..30V / 0.6A=	Type: DLS-C 30 Part No.: 500 621 Serial No.: 123456 Manufactured: 11/2009 Power: 9..30V / 0.6A=
Type: FLS-CH 10 Part No.: 600 504 Serial No.: 123456 Manufactured: 11/2009 Power: 9..30V / 2.5A=	Type: FLS-CH 30 Part No.: 600 503 Serial No.: 123456 Manufactured: 11/2009 Power: 9..30V / 2.5A=	Type: DLS-CH 15 Part No.: 500 624 Serial No.: 123456 Manufactured: 11/2009 Power: 9..30V / 2.5A=	Type: DLS-CH 30 Part No.: 500 623 Serial No.: 123456 Manufactured: 11/2009 Power: 9..30V / 2.5A=

Fig. 24: all existing type labels

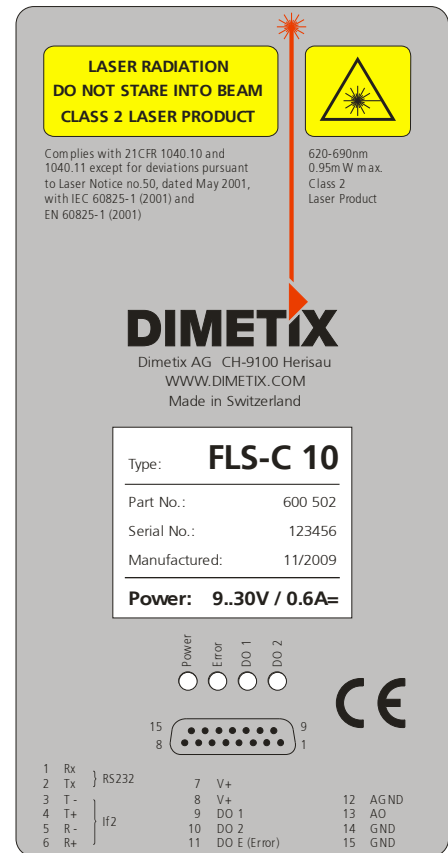

Fig. 23: DLS-C / FLS-C label inclusive type label

10.10 Laser Specification

Standard applied	EN60825-1:2007 IEC60825-1:2007
Emitted wavelength	620-690nm
Beam divergence	0.16 x 0.6 mrad
Pulse duration	$0.45 \times 10^{-9} \text{ s}$
Max. radiant power	0.95 mW

10.11 Maintenance

The DLS-C(H)/FLS-C(H) is almost maintenance free. The only thing you have to do is to clean the surfaces of the lenses.

CAUTION: Look after the surfaces of the lenses with same care that you would apply to spectacles, cameras and field glasses. Clean the optical parts only with a clean soft glasses cleaning cloth and avoid scratching of the optical parts.

10.12 Service

If you need to service the device, please contact Dimetix for instructions.

CAUTION: The warranty is void if the device is opened except the cover of the screw terminal. Removing the label is also understood as opening.

Important Notice

Dimetix reserves the right to make corrections, modifications, enhancements, improvements and other changes to its products, documentation and services at any time and to discontinue any product or service without notice. We try to give our best possible effort to provide you with perfect documents, but we can not guarantee for incorrect information. Customers should obtain the latest relevant information before placing orders and should verify that such information is up to date and complete. All products are sold subject to Dimetix terms and conditions of sale supplied at the time of order acknowledgment.

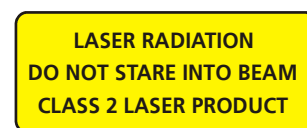

© Copyright by Dimetix

Dimetix AG
Degersheimerstr. 14
CH-9100 Herisau
Switzerland

Tel. + 41-71-353 00 00
Fax + 41-71-353 00 01
info@dimetix.com
www.dimetix.com